

Load sensing pre-compensated directional control valve

Model RM10 & RM15-MPP – Medium Pressure Platform



- ▶ Component series 1X
- ▶ Nominal pressure 4050 psi (280 bar) – pump side
- ▶ Nominal pressure 4640 psi (320 bar) – actuator side
- ▶ Nominal flow 53 gpm (200 l/min) – inlet
- ▶ RM10: Nominal flow 24 gpm (90 l/min)
- ▶ RM15: Nominal flow 40 gpm (150 l/min)

System

- ▶ Load sensing pressure compensated valves
 - Closed center for variable displacement pump
 - Direct connection between standard and high flow sections

Type

- ▶ Sectional
 - Up to eight (8) sections

Types of operation

- ▶ Hydraulic
- ▶ Electrohydraulic (proportional, on/off)

Pressure

- ▶ Inlet relief
 - Primary pressure relief valve
- ▶ Directional valve section / actuator ports
 - Work port relief valves (A and B)
 - Anti-cav valve (A and B)
 - LS pressure relief valve

Flow

- ▶ Load pressure compensated
- ▶ High repeatability
- ▶ Low hysteresis

Overview of contents

Content	Page
Features	1
Functional description / cross-section	2
Technical data	3
Ordering code	4
Port sizes	7
Directional valve sections	8
Unit dimensions	10

FUNCTIONAL DESCRIPTION

The RM Medium Pressure Platform is a compact, sectional load sensing (LS), pressure compensated valve. It has the ability to combine the standard 90 lpm section and 150 lpm section without an intermediate (transition) plate. The RM controls the volume, direction of oil flow and maintains a constant flow regardless of changing load pressures.

An advantage of the RM is that the starting point for movement of the function always remains the same, i.e., a specified control spool position always has the same metering characteristics. This is accomplished by the compensating spool in each section.

While the control spool is in the neutral position, the LS signal network is vented to tank. When the control spool is biased, the load pressure is directed to the spring end of the pressure compensator spool, the section compensator now moves to the open position. Depending on the pressure drop between the section compensator and the control spool opening, a specific volume now flows to the function. The LS signal also simultaneously communicates to the shuttle and on to the system compensating device. The system compensating device can be a variable displacement pump system.

▼ Sectional view

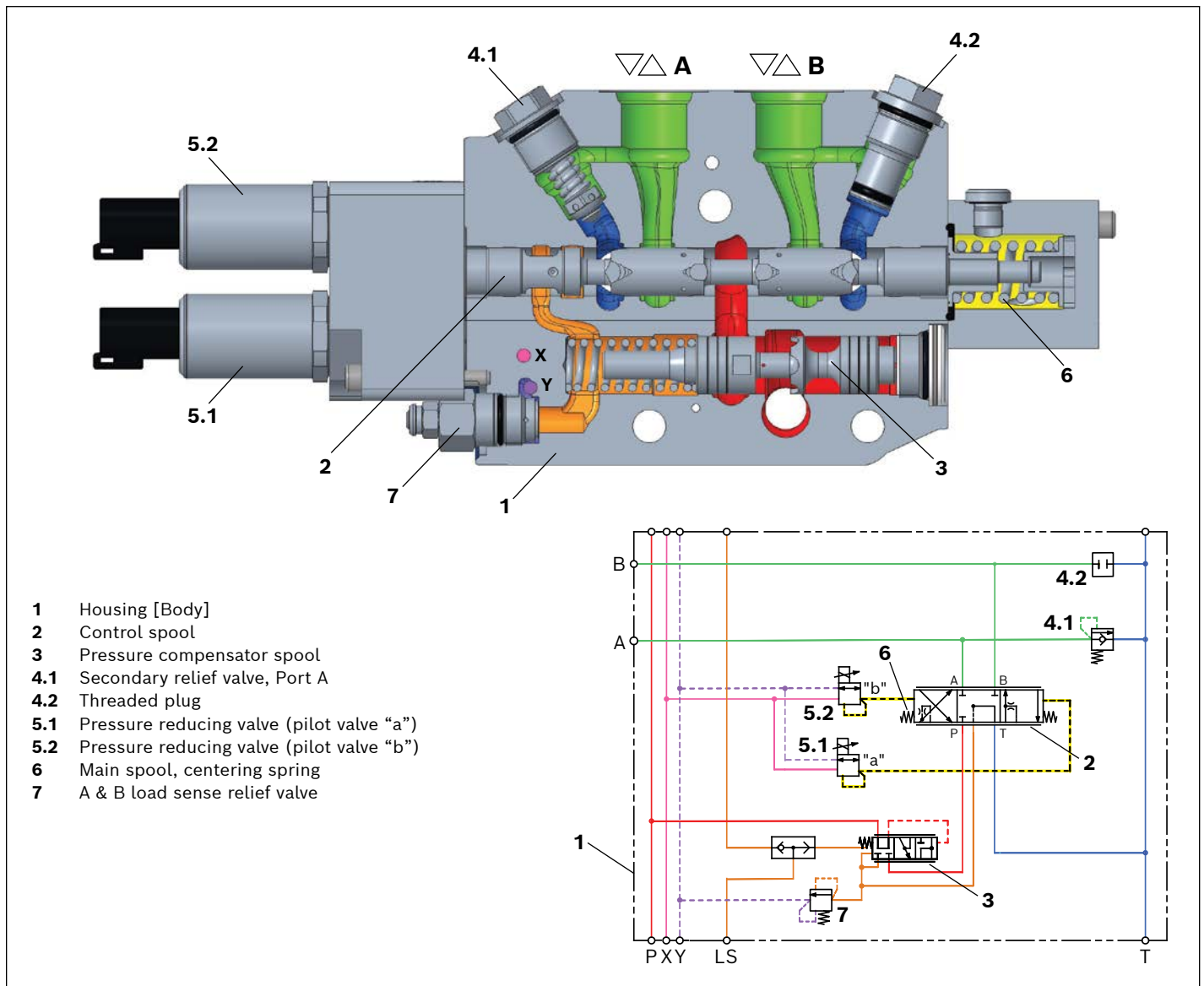

TECHNICAL DATA

(Please inquire in case the intended use of unit is outside the given values!)

General				
Installation Position	Ideally horizontally to the spool axis			
Type of connection	UNF: SAE J1926 / ISO 11926-1 BSPP: (DIN 3852-2) / ISO 228 (inches)			
Hydraulic fluid and ambient temperature range	9	°F (°C)	-4 ... +176 (-40 ... +212 on request) -20 ... +80 (-40 ... +100 on request)	
Hydraulic				
Max. flow at port	P	q_{vmax}	gpm (l/min)	53 (200)
	RM10: A, B	q_{vmax}	gpm (l/min)	24 (90)
	RM15: A, B	q_{vmax}	gpm (l/min)	40 (150)
Max. operating pressure at port	P	p_{max}	psi (bar)	4050 (280)
	A, B	p_{max}	psi (bar)	4640 (320)
	T (EH & Pilot)	p_{max}	psi (bar)	725 (50)
Max. pilot pressure at port	X	p_{ctrl}	psi (bar)	500 (35)
	a, b	p_{ctrl}	psi (bar)	500 (35)
Pilot Pressure range (Refer to pages 7 & 8)	Hydraulic	p_{ctrl}	psi (bar)	Consult factory – 145 to 435 (10 to 30)
	Electrohydraulic	p_{ctrl}	psi (bar)	Consult factory – 145 to 435 (10 to 30)
Min. pump margin		p_{min}	psi (bar)	261 (18)
Hydraulic fluid	Mineral oil (HL, HLP) according to DIN 51524, other hydraulic fluids, such as HEES (synthetic esters) according to VDMA 24568 as well as hydraulic fluids as specified under RE 90221, at request			
Viscosity range	ν	SUS (cSt)	46 to 1760 (10 to 380)	
Maximum admissible degree of contamination of the hydraulic fluid cleanliness level according to ISO 4406 (c)				Class 20/18/15, we recommend a filter with a minimum retention rate of $\beta_{10} \geq 75$
Electrical				
Type of voltage	DC			
Nominal voltage of the amplifier	Vdc	12		24
Maximum control current	A	See RE 58032		
Coil resistance (20 °C)	Ω	See RE 58032		
Duty cycle (with amplifier)	%	100		
Protection class according to DIN 40050-9	– Solenoid	See RE 58032		
	– Electric connection	K40	IP67 and IP69K	
PWM frequency (recommended) ¹⁾				180

1) The PWM frequency is to be optimized depending on the application.
In this regard, observe the temperature range of the application.

4 **RM10 & RM15-MPP** | Load sensing pre-compensated directional control valve
Ordering code

ORDERING CODE

01	02	03	04	05	06	07	08	09	10	11	12	13	14	15	16	17	18	19
RM		S	1		S		Z	ZZ					Z	Z			S	00

Type

01	RM	RM
----	----	----

Size

02	10	10
	15	15

Body

03	MP Standard	S
----	-------------	---

Index of series

04	Series Index 1	1
----	----------------	---

Thread Type

05	Standard UN (F) ports per SAEJ1926-1 / ISO11926-1	S
	BSPP parallel pipe thread ports per DIN 3852-2 / ISO 228 (inches)	G

Pressure compensator

06	Standard load holding	S
----	-----------------------	---

Common LS relief

07	LS relief cavity plugged		QQ	
		LS relief valve setting	160 Bar / 2300 PSI	16
			180 Bar / 2600 PSI	18
			200 Bar / 2900 PSI	20
			220 Bar / 3200 PSI	22
			240 Bar / 3500 PSI	24
			260 Bar / 3800 PSI	26
			280 Bar / 4100 PSI	28

Additional options

08	None	Z
----	------	---

Separate B side LS relief valve

09	None	ZZ
----	------	----

Spool configuration

10	Closed center spool	E
	Motor spool	J
	Float spool	W

Spool flow – Liters Per Minute (lpm)

		A	B	
11-12	RM10 E spools 1:1 symmetric ratio	5.3 – 5.3 GPM	020	020
		7.9 – 7.9 GPM	030	030
		10.6 – 10.6 GPM	040	040
		17.2 – 17.2 GPM	065	065
		23.8 – 23.8 GPM	090	090
	RM15 E spools 1:1 symmetric ratio	29.1 – 29.1 GPM	110	110
		34.3 – 34.3 GPM	130	130
		39.6 – 39.6 GPM	150	150
	RM10 E spools 1:1.5 asymmetric ratio	7.9 – 5.3 GPM	030	020
		10.6 – 7.1 GPM	040	027
		17.2 – 11.4 GPM	065	043
		23.8 – 15.9 GPM	090	060

ORDERING CODE

01	02	03	04	05	06	07	08	09	10	11	12	13	14	15	16	17	18	19
RM		S	1		S		Z	ZZ					Z	Z			S	00

Spool flow – Liters Per Minute (lpm) continued

		A		B	
11-12	RM15 E spools 1:1.5 asymmetric ratio	29.1 – 19.3 GPM	110	-	073
		30.4 – 23 GPM	115	-	087
		34.3 – 23.0 GPM	135	-	095
		39.6 – 26.4 GPM	150	-	100
RM10 J spools 1:1 symmetric ratio	6.6 – 6.6 GPM	025	-	025	
	10.6 – 10.6 GPM	040	-	040	
	17.2 – 17.2 GPM	065	-	065	
	23.8 – 23.8 GPM	090	-	090	
RM15 J spools 1:1 symmetric ratio	29.1 – 29.1 GPM	110	-	110	
	30.4 – 30.4 GPM	115	-	115	
	35.7 – 35.7 GPM	135	-	135	
	39.6 – 39.6 GPM	150	-	150	
W spools, A side 4 th position float		A (power)		B	
RM10 MPP	7.9 – 18.5 GPM	030	-	070	
RM15 MPP	10.6 – 23.8 GPM	040	-	090	

A side actuations

13	DT04-2P (Deutsch) 12V proportional electric pilot	D1
	DT04-2P (Deutsch) 24V proportional electric pilot	D2
	Junior Timer 2-pin (AMP) 12V proportional electric pilot	J1
	Junior Timer 2-pin (AMP) 24V proportional electric pilot	J2
	Hydraulic pilot (Port type determined by 04)	HP

A side actuation additional options

14	None	Z
----	------	----------

B side actuation / lever specification

15	None	Z
	override without handle	O
	override standard handle / 60° upwards	U
	override standard handle / 0° straight	S
	override standard handle / -60° downwards	D

A port secondary options

16	Cavity plugged	QQQ	
	Check valve for anti-cavitation	QCV	
	Shock valve with anti-cavitation	200 Bar / 2900 PSI	H20
		240 Bar / 3500 PSI	H24
		280 Bar / 4100 PSI	H28
		300 Bar / 4350 PSI	H30
320 Bar / 4600 PSI	H32		

Consult factory

Ordering Code continued on next page.

6 **RM10 & RM15-MPP** | Load sensing pre-compensated directional control valve
 Ordering code

ORDERING CODE

01	02	03	04	05	06	07	08	09	10	11	12	13	14	15	16	17	18	19
RM		S	1		S		Z	ZZ					Z	Z			S	00

B port secondary options

17	Cavity plugged		QQQ	
	Check valve for anti-cavitation		QCV	
	Shock valve with anti-cavitation	200 Bar / 2900 PSI		H20
		240 Bar / 3500 PSI		H24
		280 Bar / 4100 PSI		H28
		300 Bar / 4350 PSI		H30
320 Bar / 4600 PSI			H32	

Seal type

18	Standard HNBR	S
----	---------------	----------

Special designation

19	Code 00-ZZ	00
----	------------	-----------

PORT SIZES

	Ports	SAE (SAE J1926-1 / ISO 11926-1)	BSPP (DIN 3852-2)
RM10-MPP	A & B work ports	SAE-10 7/8" - 14 UNF-2B Thread	G 1/2"
	Hydraulic pilot ports X_a & X_b (if available)	SAE-6 9/16 - 18 UNF-2B Thread	G 1/4"
RM15-MPP	A & B work ports	SAE-12 1 1/16" - 12 UN-2B Thread	G 3/4"
	Hydraulic pilot ports X_a & X_b (if available)	SAE-6 9/16 - 18 UNF-2B Thread	G 1/4"

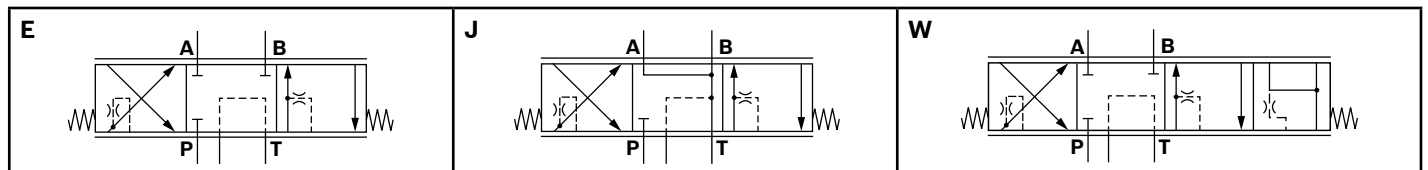
SPOOL SYMBOLS

DIRECTIONAL VALVE SECTIONS: CONTROL SPOOL

Spool characteristic curves (Symmetrical E)

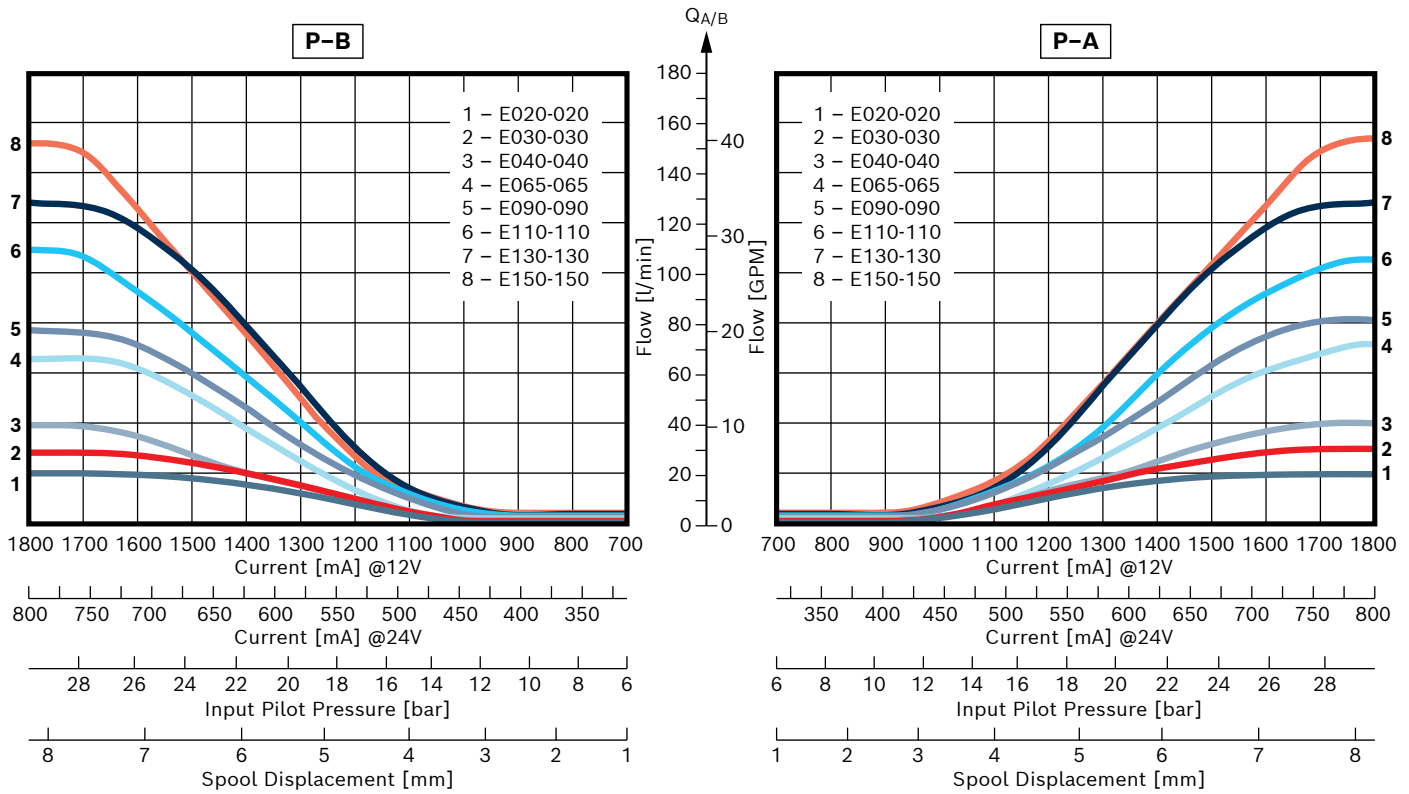

Spool characteristic curves (Asymmetrical E)

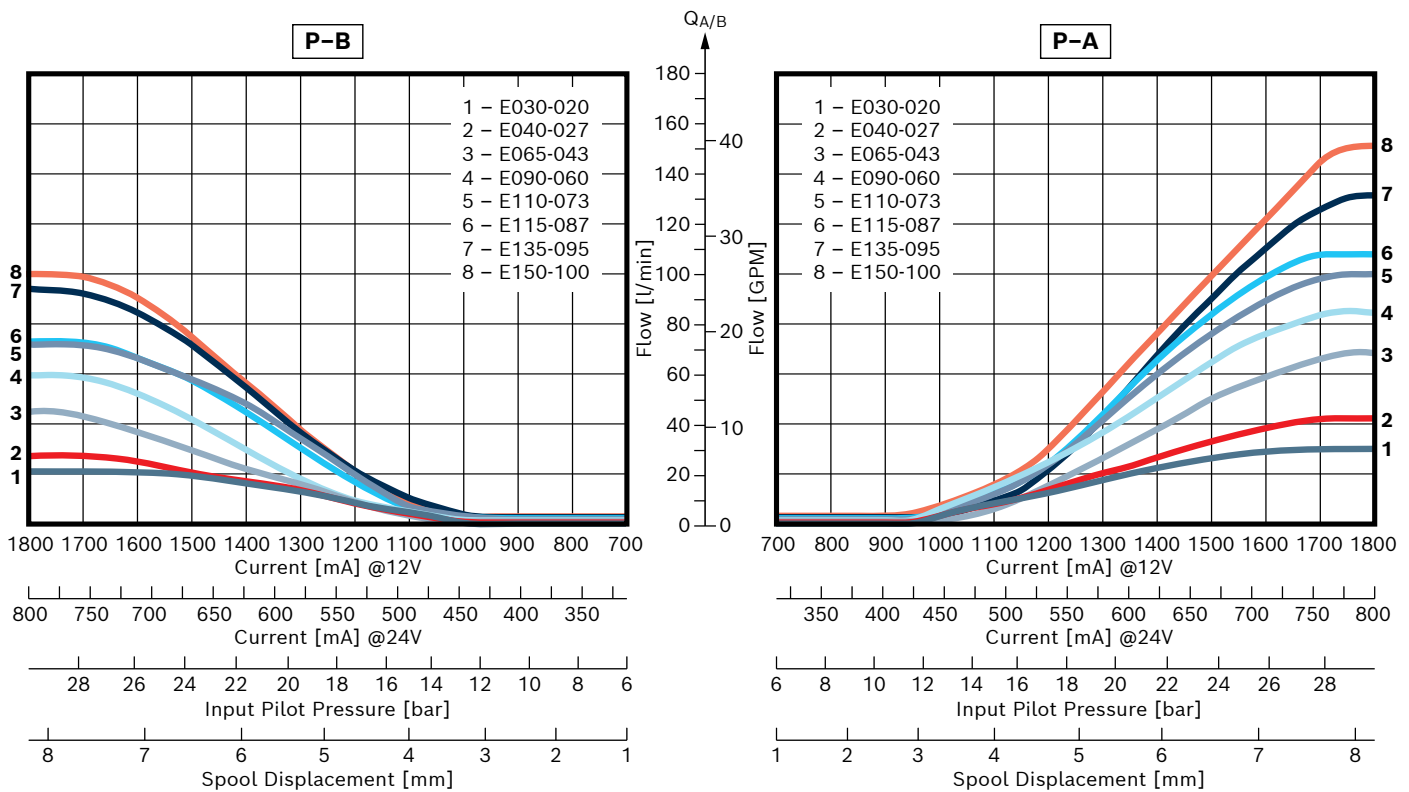

DIRECTIONAL VALVE SECTIONS: CONTROL SPOOL

Spool characteristic curves (Symmetrical J)

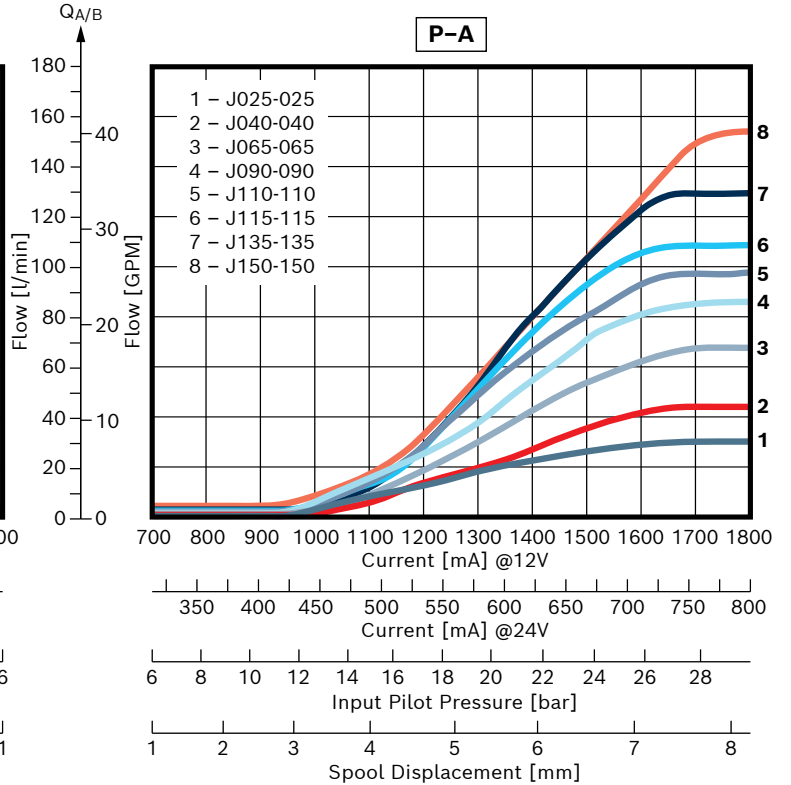
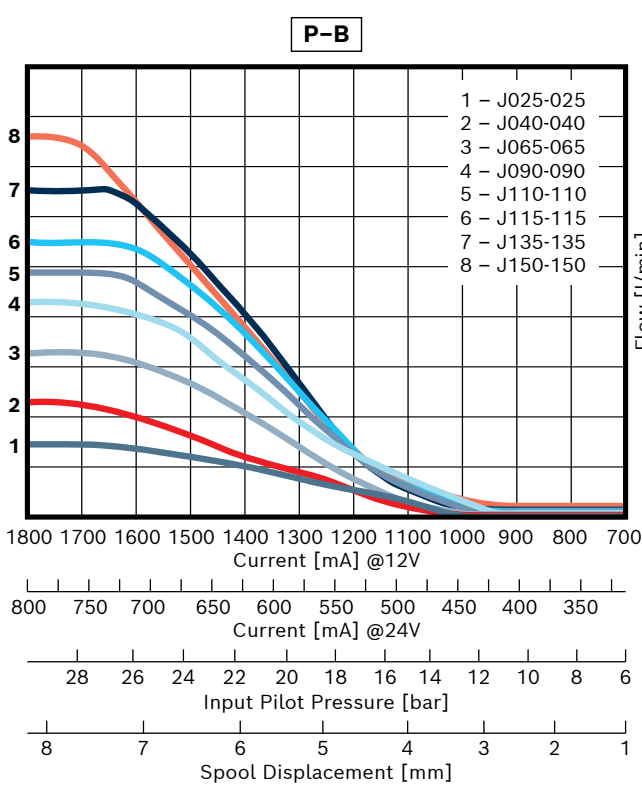

Spool characteristic curves (Float W)

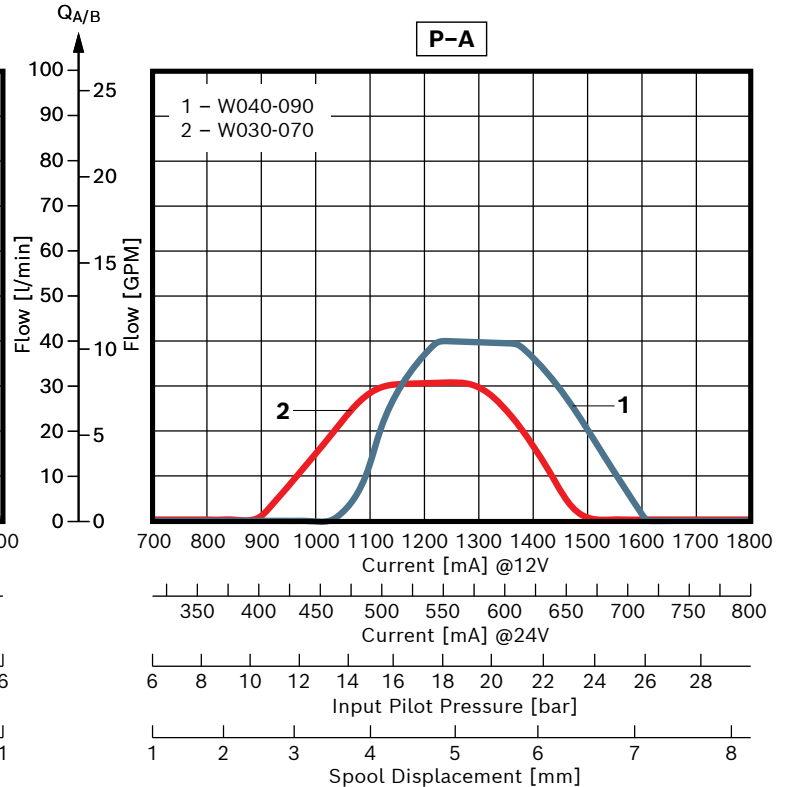
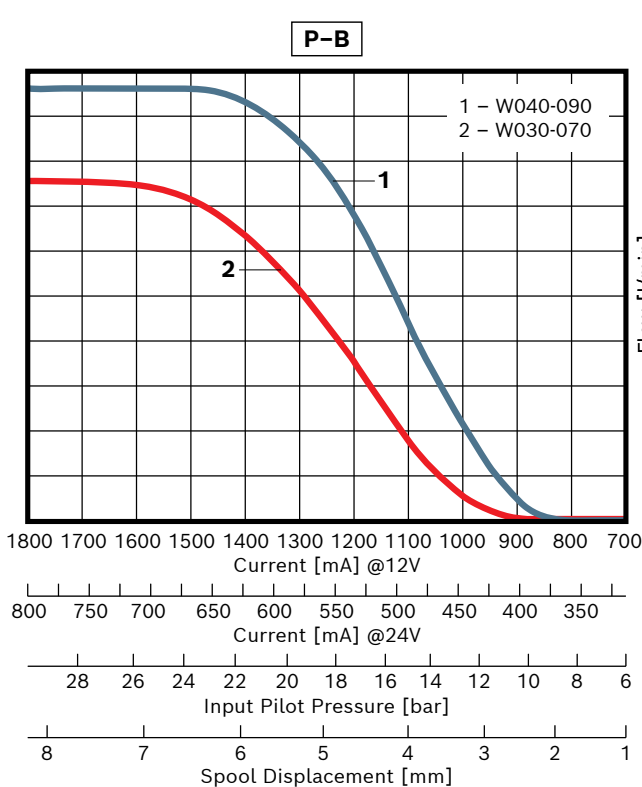

UNIT DIMENSIONS [mm] – RM10-MPP

Proportional electric pilot
 (Reference dimensions)

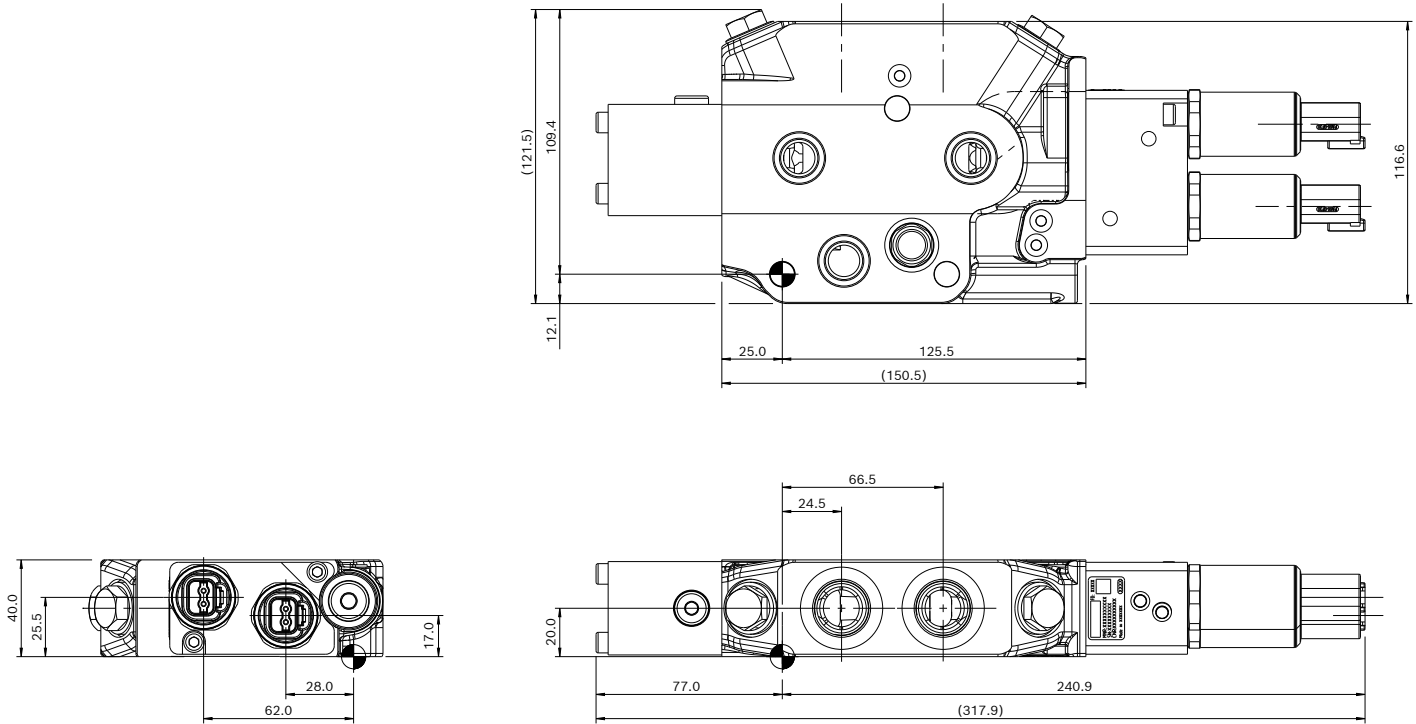

Hydraulic pilot
 (Reference dimensions)

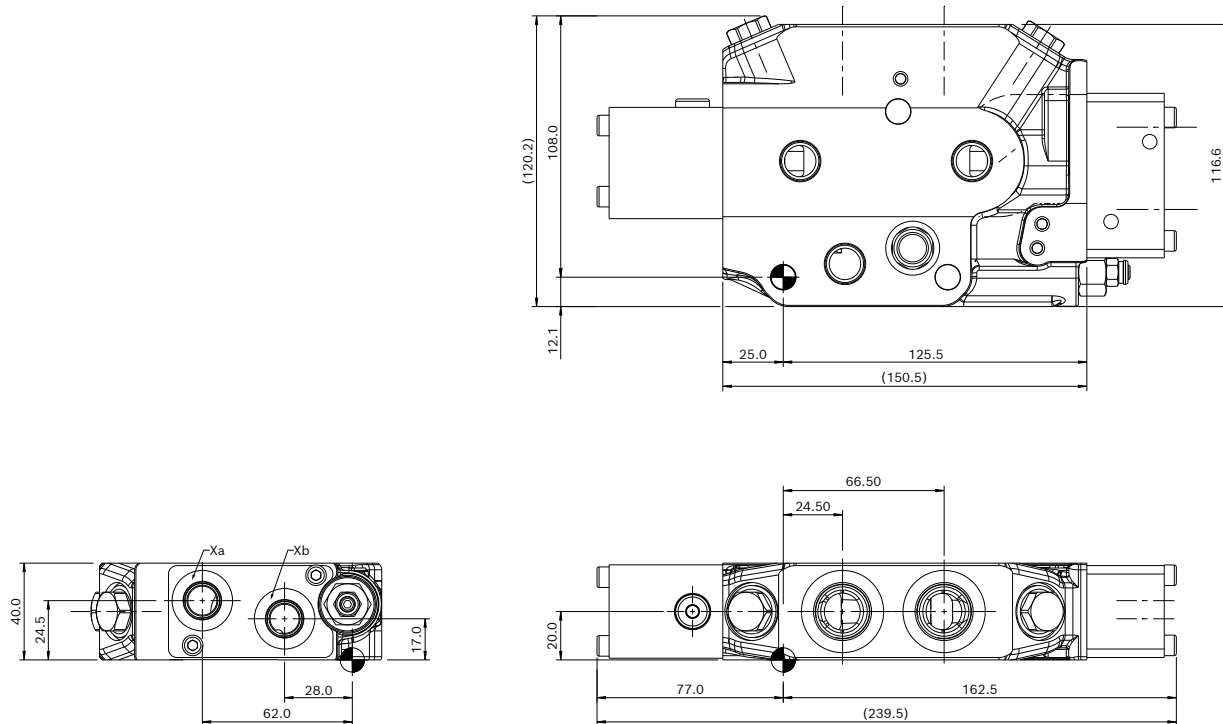

UNIT DIMENSIONS [mm] – RM15-MPP

Proportional Electric Pilot
 (Reference dimensions)

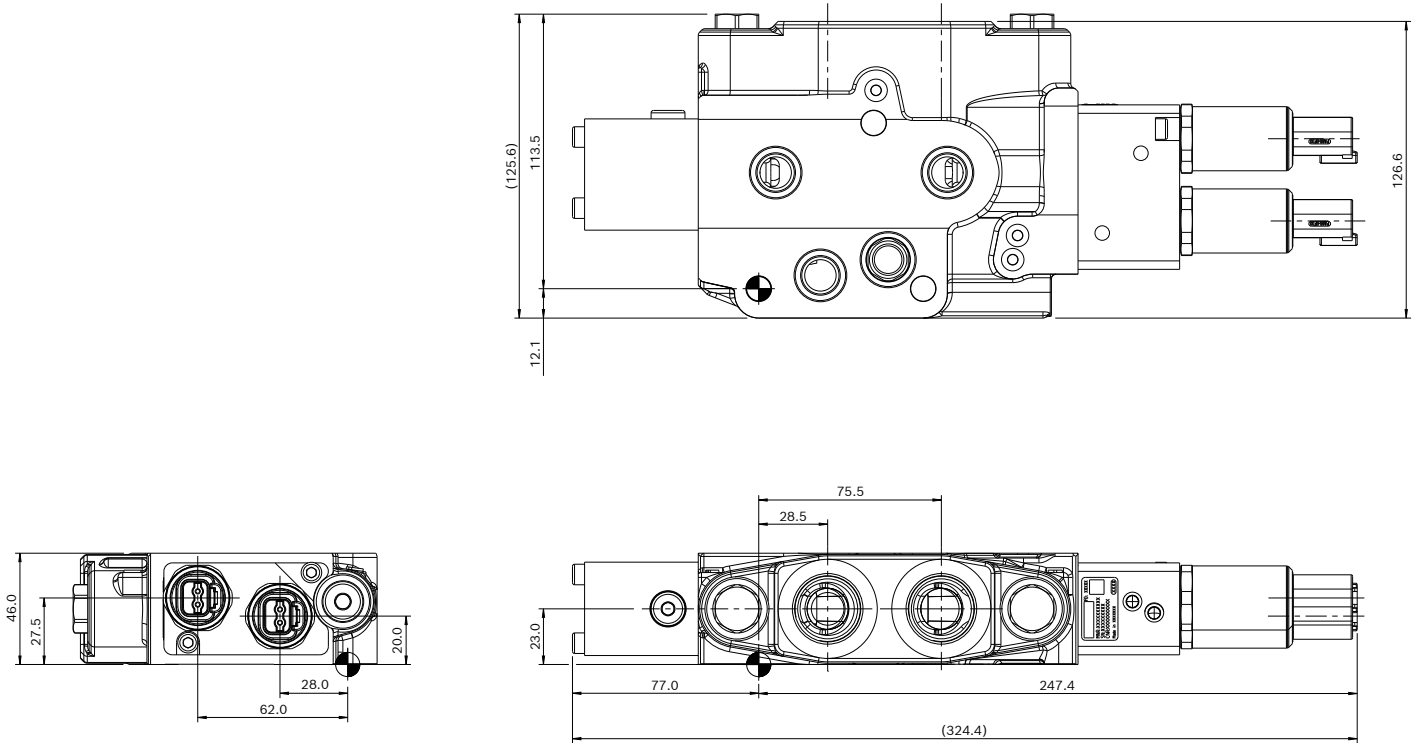

Hydraulic Pilot
 (Reference dimensions)

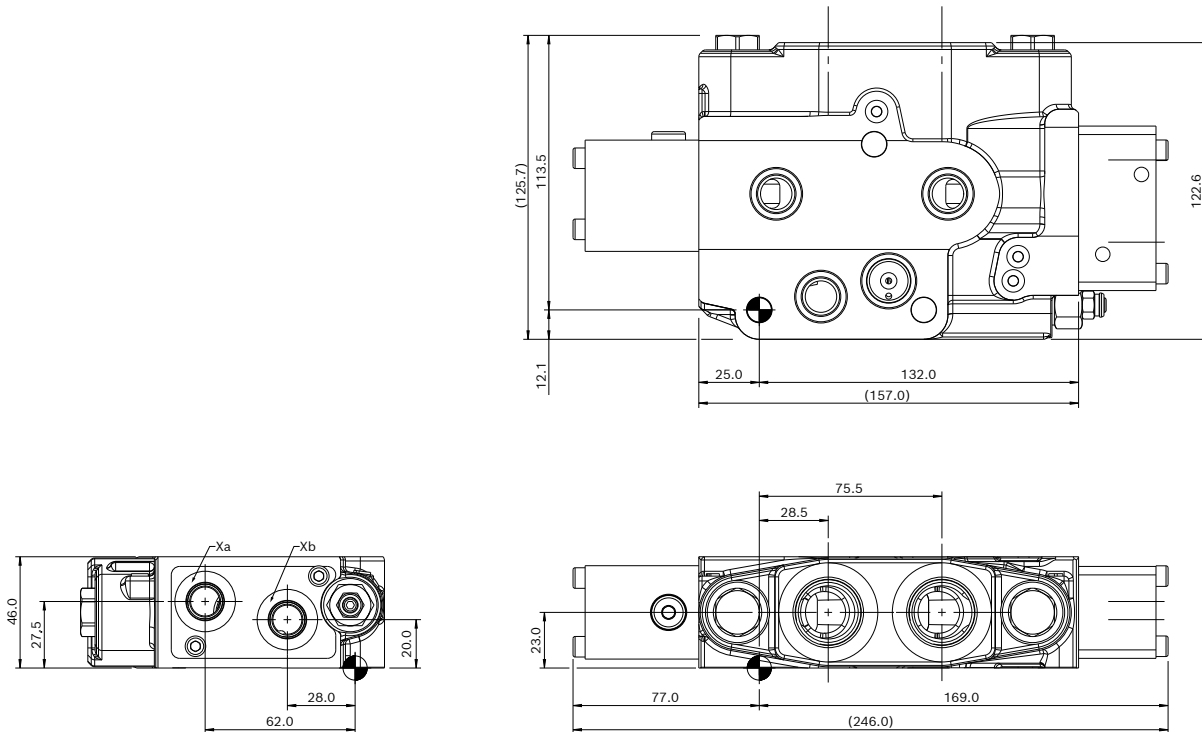

NOTES

Bosch Rexroth Corporation
Hydraulics
8 Southchase Boulevard
Fountain Inn, SC 29644-9018
U.S.A.
Telephone (800) REXROTH
(800) 739-7684
info@boschrexroth-us.com
www.boschrexroth-us.com

© All rights reserved Bosch Rexroth Corp. This document, as well as the data, specifications and other information set forth in it, are the exclusive property of Bosch Rexroth Corp. It may not be reproduced or given to third parties with its consent.

The data specified above only serve to describe the product. No statements concerning a certain condition or suitability for a certain application can be derived from our information. The information given does not release the user from the obligation of own judgment and verification. It must be remembered that our products are subject to a natural process of wear and aging.

SUBJECT TO REVISION.