

Sytronix

variable-speed

pump drives

energy-efficient,

intelligent, cost-effective



Sytronix type variable-speed pump drives change the game with hydraulic systems and offer new opportunities for innovative designs. Energy-efficient solutions using components matched to the application and an in-depth knowledge of the technology are key.

Investment in energy saving technology using Bosch Rexroth hydraulics can provide fast returns, with energy savings up to 80 percent.





**WE MOVE.
YOU WIN.**

04 SYTRONIX – ENERGY-EFFICIENT VARIABLE-SPEED PUMP SYSTEMS

- 06 System overview
- 08 Product selection guide

12 SYTRONIX PRESSURE CONTROL SYSTEMS

- 13 FcP 5020
- 19 DRn 5020

22 SYTRONIX p/Q CONTROL SYSTEMS

- 24 SY(H)DFEn

27 SYTRONIX P/Q, F/x AXIS CONTROL SYSTEMS

- 28 SvP 7020
- 33 SvP 5020

39 SYTRONIX – INDIVIDUAL SOLUTIONS

- 40 8 steps for a system solution
- 41 Selection of individual components

42 SYTRONIX RETROFIT

43 SYTRONIX SIZE

44 COMPONENTS AND MODULES

- 45 Motor-pump combinations
- 48 Drives
- 57 Motors
- 61 Pumps
- 69 Accessories

Sytronix – energy-efficient variable-speed pump systems

Older machine designs focused on systems that had the capacity to deliver maximum performance, even though it might have only been for a fraction of the complete cycle. Today there is a greater emphasis on reducing energy consumption and noise emissions. Higher energy prices and workplace environmental requirements have engineers rethinking their designs.

Using Sytronix (smart interplay of hydraulics and electronics) variable-speed pump drives can address these issues by combining the advantages of Bosch Rexroth technologies: reliability of high-performance hydraulics and energy efficiency and dynamics of powerful drives and electronic systems.

Sytronix drives combine matched electric motors, hydraulic pumps, and frequency converters, which has the potential of significant energy savings and a considerable reduction in noise emissions at a cost that provides an attractive return on investment.

Energy on Demand – powerful hydraulics, intelligent control

By combining the advantages of hydraulics with the control intelligence of electrical drives, motor speeds can be continuously adjusted to match the machine’s requirements. The drive speed of the pump can be lowered to an energy-efficient, quiet level when the process requires less than full performance. By having a major portion of the machine cycle time adapted to the part-load requirement, energy is saved and noise is reduced. Sytronix systems are part of Bosch Rexroth’s **4EE-Strategie** for system energy reduction.

4EE – THE UNIVERSAL SYSTEMATICS REXROTH FOR ENERGY EFFICIENCY

Energy System Design

Systematic overall view, project planning, simulation, consulting



Efficient Components

Products and systems with optimized efficiency



Energy Recovery

Recovery and storage of excessive energy



Energy on Demand

Energy usage on demand, stand-by mode



Application in the entire machine life cycle





WHY VARIABLE-SPEED PUMP SYSTEMS?

Reduced energy consumption

- + Energy savings of up to 80% decrease energy costs
Reduce CO₂ carbon footprint

Lower noise emission

- + Sytronix type drives can reduce the noise emission of the hydraulic power unit up to 20 dB (A)
Meeting stringent requirements on noise emissions in certain market areas is easier

Easier cooling

- + By lowering the average pump drive speed, variable-speed pump drives can significantly reduce the temperature, minimizing the cost and energy required to cool the hydraulic system

Less space required

- + Reduced hydraulic fluid volume resulting in smaller reservoir requirements
- + Less space required for cooling due to reduced heat loads and elimination of most noise containment components
- + The compact MS2N motor saves additional space

More reliable operation

- + Integrated system design using proven hydraulic and electrical components
- + Condition monitoring and diagnosis available in the drive control electronics



WHY SYTRONIX FROM REXROTH?

Optimized pressure controller

- + Many frequency converters contains PID controller, which can be used for a wide range of applications. Our controller structure is optimized for non-linear and elastic characteristic of hydraulics. It means that the dynamic is perfect and accumulator size can be reduced and the pressure drops are as low as possible

Switchable pressure and flow command values

- + You need switchable pressure/flow values? In FcP and SvP you can easily store different command values and call them up by digital input. Automatic power limitation reduce the flow according to the actual pressure, for easy handling of fast movement and pressing phases

Accumulator charging and hydraulic soft start

- + In stand-by operation the drive switches off and automatically back on depending on the demand and a user-defined minimum accumulator pressure. The soft start function starts the pump with reduced command values. Both functions extend the life time of your hydraulic components

Hydraulic gear

- + In partial load operation, the variable displacement pumps in system DRn and SY(H)DFEn is able to reduce the motor torque by controlling the pump displacement. The system controls the speed and displacement in order to archive best energy-efficiency. In many cases it is possible to downsize the motor by using hydraulic gear

Always the right Sytronix system

Variable-speed pump drives offer a comprehensive range of pumps, controllers, motors and software to suit a wide spectrum of applications. Rexroth provides machine manufacturers support during project planning, utilizing simulation models for system design and component selection.

Scalability of performance and function allows for an optimal choice of system components. When using a cascade system, multiple Sytronix drives can work together to efficiently generate the flow rate required for the process. Sytronix systems are available as pre-configured systems or as individually configured components.

SETS FOR PRESSURE CONTROL SYSTEMS (p)

► DRn

DRn is a powerful system for the performance range from approx. 4 kW (5 hp). The system distinguishes itself by good dynamics and high overload capacity. The pump independently controls the necessary pressure and the frequency converter automatically determines the load and sets the perfect speed for the operating point. The system is perfectly suited for retrofitting existing systems as most DR and DRG pumps can be used.

► FcP

FcP systems are designed for pressure control systems and distinguish themselves by a very low noise level. Application examples include machine tools and small power units. SY(H)DFEn systems are suitable for applications with high performance, high demands on dynamics, performance and control quality. These systems utilize pump systems based on axial piston pumps with variable flow and variable pressure. They are particularly suitable for retrofit in existing systems up to 18.5 kW (25 hp). With special noise requirements or requirements such as HFC, the use of FcP is also reasonable at a higher performance range up to approximately 90 kW (125 hp).

SETS FOR PRESSURE AND FLOW CONTROL (p/Q)

► SY(H)DFEn

SY(H)DFEn systems are suitable for applications with high performance, high demands on dynamics, performance and control quality. These systems utilize pump systems based on axial piston pumps with variable flow and variable pressure. They are particularly suitable for retrofit in existing systems.

SETS FOR AXIS CONTROL SYSTEMS (p/Q, F/x):

► SvP

SvP systems use the high dynamics of servo motors (permanent magnet) to achieve significant energy savings. Capabilities include axis control functions in both open and closed hydraulic circuits requiring high dynamic performance, as well as advanced electrical and electrohydraulic controls. Plastics machines and press lines are key sectors for this technology.

Sytronix

Variable-speed pump drives

p

PRESSURE CONTROL SYSTEMS



1

- FcP 5020**
0.25 to 18.5 (90) kW
(0.3 to 25 (125) hp)
- ▶ Very low noise level
 - ▶ Standard dynamics

- DRn 5020**
4 to 160 kW
(5 to 200 hp)
- ▶ High overload capacity
 - ▶ High control quality
 - ▶ Medium dynamics

p/Q

SYSTEMS FOR PRESSURE AND FLOW CONTROL



- SY(H)DFEn**
18,5 to 315 kW
(25 to 420 hp)
- ▶ Optional HFC
 - ▶ Multiple pumps
 - ▶ High dynamics

- SvP 5020**
9 to 65 kW
- ▶ Pressure and flow control
 - ▶ Very high dynamics

p/Q

SYSTEMS FOR AXIS CONTROL

F/x



- SvP 7020**
9 to 80 kW
(12 to 100 hp)
- ▶ Position control
 - ▶ Pressure and flow control
 - ▶ Very high dynamics

Product selection guide

INFORMATION REGARDING THE SELECTION OF PRE-CONFIGURED SYSTEMS

2 Drive unit	EFC 5610 (for systems 5020)	IndraDrive HCS or HMV/HMS (for systems 7020)
Interface	Analog/digital, Sercos & Multi-Ethernet, Profibus	Analog/digital, Sercos & Multi-Ethernet, Profibus
Functionality	<ul style="list-style-type: none"> ▶ Alternating p/Q control ▶ Single-axis drive 	<ul style="list-style-type: none"> ▶ Alternating p/Q control ▶ Position and force control ▶ Integrated PLC for optimizing the machine performance ▶ i4.0-enabled (condition monitoring) ▶ Single- and multi-axis drives allow for kinetic buffering, energy exchange, etc.
Pump guard	Basic	Advanced
Performance	+	++
Commissioning	Display, IndraWorks DS	IndraWorks DS

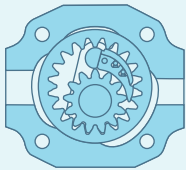
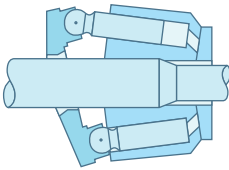
3 Pump	Internal gear pump		Axial piston pump		
					
	Thanks to the particularly low noise level of the internal gear pump, additional noise insulation at the power unit is usually not necessary.		In many cases, reduction of the torque in partial load operation allows for smaller motor ratings. The drain port of the pump provides for sufficient lubrication and cooling without external measures.		
Type	PGF	PGH	A10	A15	A4
n_{\min} bei p_{cont} [rpm]	200	200	50	50	50
n_{\max} [rpm]	3600	3000	3600 ... 1800	2400 ... 1800	2600 ... 1500
V_{geo} [cm ³]	1.7 ... 40	20 ... 250	6 ... 180	110 ... 280	40 ... 750
p_{cont} [bar]	250	315	315	350	350
p_{\max} [bar]	350	350	350	420	400
P_{hydmax} [kW (hp)]	34 (45)	134 (180)	151 (220)	294 (395)	656 (880)
Operating mode	2, 1 – Q	2, 1 – Q	4, 2, 1 – Q	2, 1 Q	4, 2, 1 – Q
Documentation	RD10213	RD10227	RD91485	RD92800	RD92050

Motor	MOT-FC	MSK/MS2N
Dynamics (acceleration ¹⁾)	>300 ms	<100 ms
Position control ²⁾	-	++
Minimum speed ³⁾	100 rpm	0 rpm
Dimensions	O	+

¹⁾ Acceleration to 1500 rpm

²⁾ Only possible with IndraDrive

³⁾ Normally the pump is the limiting component in the system

6 STEPS FOR CHOOSING A SYTRONIX SYSTEM

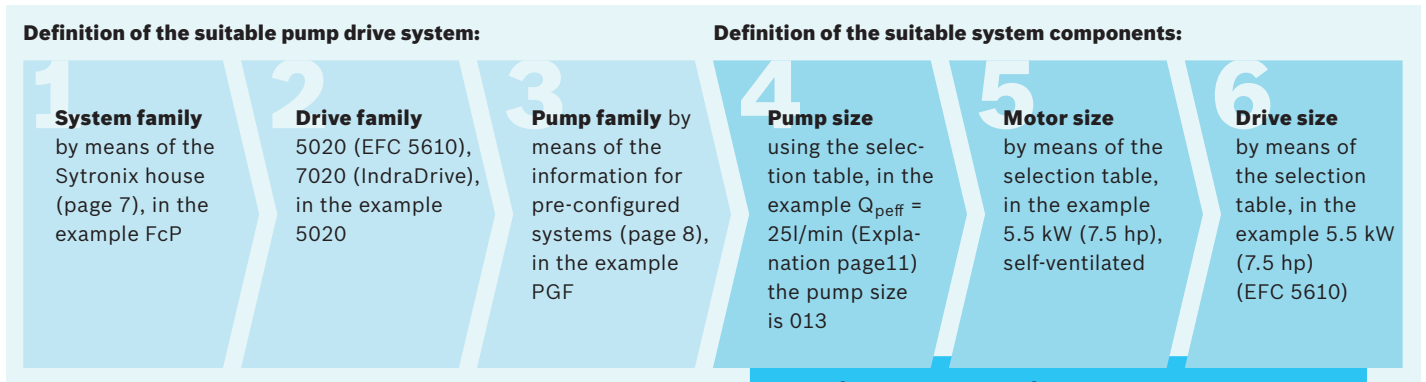

Example pressure control system:
 Q_{peff} : 25 l/min flow
 p_{const} : 103 bar working pressure

Product selection guide for Sytronix FcP 5020 with PGF

Pumps ¹⁾ $n_{max} = 3600$ rpm						Motors												
Type	Size	p_{cont} [bar]	p_{max} [bar]	Q_{pRMS} [l/min]	Q_{max} [l/min]	MOT-FC IC 411/TEFC (self-ventilated)												
						P_{nom} [kW]												
						0.25	0.37	0.55	0.75	1.10	1.5	2.2	3	5.5	7.5	11	15	
						4200	4200	4200	4200	4200	4200	4000	4000	4000	4000	3800	3800	
						p_{RMS}^* [bar]												
						n_{max} [rpm]												
PGF1	1.7	180	210	3.6	6	34	65	96	129	180								
	2.2	210	250	4.6	7	27	50	74	100	148	198	210						
	2.8	210	250	5.9	10	23	39	58	79	116	156	210						
	3.2	210	250	6.7	11	18	34	51	69	102	136	199	210					
	4.1	210	250	8.6	14		27	40	54	79	106	156	210					
PGF2	5	180	210	10.5	18		22	33	44	65	87	128	176	180				
	006	210	250	14	23		17	25	34	50	67	98	135	176	210			
	008	210	250	17	29			20	27	40	53	78	107	139	193	210		
	011	210	250	23	39				20	30	40	58	80	104	144	196	210	
	013	210	250	28	47				17	24	33	48	66	86	119	162	210	
	016	210	250	34	57					20	27	40	55	71	99	135	198	210
	019	210	250	40	68					17	23	34	47	61	84	114	168	210
	022	180	210	46	66						20	29	40	52	72	98	144	180
Pump Drives						K [%]												
EFC5610	OK40					167	118											
	OK75					295	209	148	124									
	1K50							258	216	148	118							
	2K20									207	165							
	3K00											122						
	4K00											161	121					
	5K50											159	159					
	7K50													115	153			
	11K0														112	162	116	
	15K0															154	116	

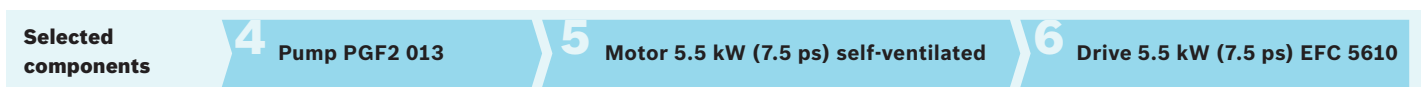

Type key of the main components	1	2	3	4	5	6
	R900943181	PGF2-2X/013RE20VE4				Internal gear pump
	R911340643	MOT-FC-ET2-*BV-132S-4-5CB-05,5-A3T-HOY				Motor
	R912007542	EFC5610-5K50-3P4-MDA-7P-FCPNN-L1NN				Pump drive
	R912006013	FEAM03.1-002-NN-NNNN				Shield connection*
	R901342027	HM 20-2X/250-H-K35				Pressure transducer*

* The listed components serve the exemplary representation of the parts list and cannot be determined using the shown guide

SYTRONIX GUIDE FOR THE SELECTION OF PRE-CONFIGURED SYSTEMS

All components required to configure a Sytronix system are available separately (see "Components and modules", page 46). The Rexroth specialists will be willingly prepared to support you in the selection.

The steps and guides for the product selection are described from page 42 in the section "Individual solutions".

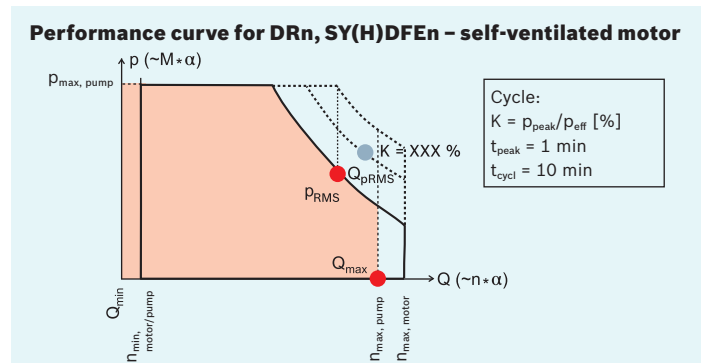
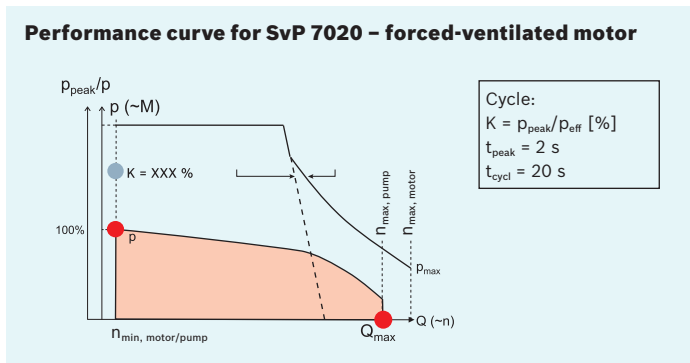
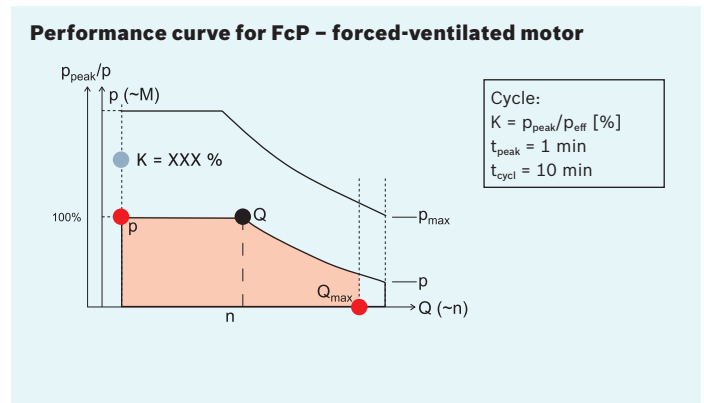
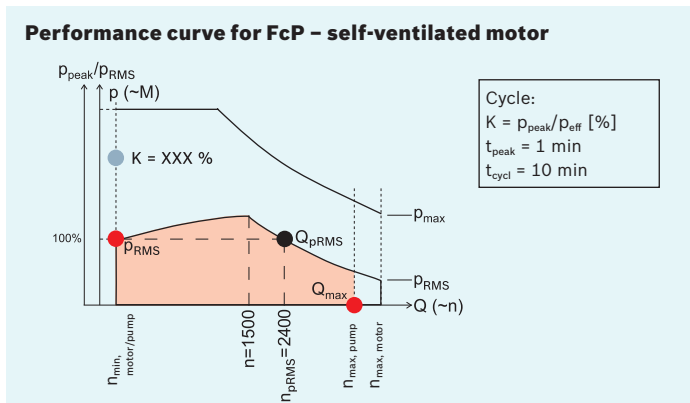

- ▶ Q_{max} : Maximum flow at maximum system speed
- ▶ Q_{pRMS} : Flow capacity at RMS pressure (the speeds necessary for the calculation are available on the page of the relevant system family)
- ▶ p_{RMS} : RMS pressure is the thermally effective pressure. At constant pressure, the RMS pressure equals the system pressure. If the pressure changes over the time, the RMS pressure is calculated as follows:

$$p_{RMS} = \frac{\sqrt{p_1^2 \cdot t_1 + p_2^2 \cdot t_2 + \dots + p_n^2 \cdot t_n}}{t_1 + t_2 + \dots + t_n}$$

- ▶ K: power factor → peak pressure / RMS pressure in percent – e.g.: 38 % overload capacity → $K = 138$
- Observe the admissible time share for the peak pressure in the tables above. For accelerations, the drive may also be subjected to higher loads.

SYTRONIX-KONFIGURATIONSLEITFADEN FÜR DRUCKREGELSYSTEME – Z. B. FcP 5020-LÖSUNGEN

Using a self-ventilated motor (designation: IC 411 / TEFC) and a pump with constant flow allows for maintaining the system pressure p_{RMS} specified in the product selection guides beyond the nominal motor speed of 1500 rpm up to a speed of 2400 rpm. With an internal gear pump of type PGF2 013, the corresponding flow is calculated as follows (without efficiency): $Q_{p_{RMS}} = (n \cdot V) / 1000 \rightarrow Q_{p_{RMS}} = (2400 \text{ rpm} \cdot 13 \text{ cm}^3) / 1000 \rightarrow Q_{p_{RMS}} = 31 \text{ l/min}$. At a pressure of p_{RMS} of 119 bar (without efficiency), as specified for PGF2 013, it is, for example, possible to keep this pressure constant at a flow of 31 l/min.

The flow value of 47 l/min specified in the product selection guide always refers to the maximum possible speed of either the hydraulic pump $n_{max, pump}$ or the asynchronous motor $n_{max, motor}$. This value of 47 l/min can only be achieved temporarily at reduced pressure.

The minimum speeds for the hydraulic pump $n_{min, pump}$ and the asynchronous motor $n_{min, motor}$ depend on the selected Sytronix system and the system pressure. For instance, refer to the following diagram for the PGF2 pump.

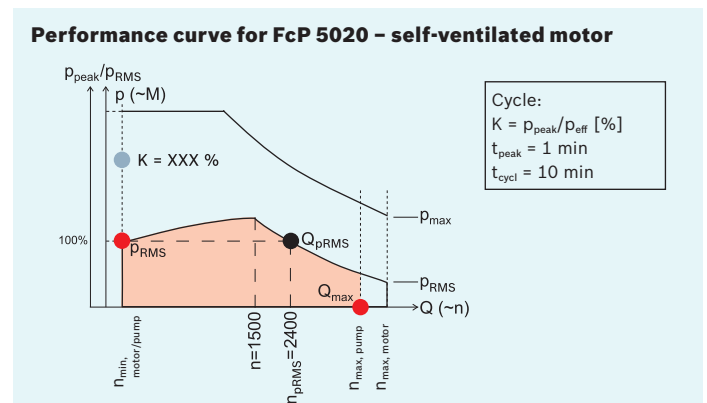

Sytronix for pressure control systems FcP and DRn

For pressure control systems, two Sytronix systems are available which differ considerably in the principle of operation and in applications. FcP is a smart solution, especially with small to medium performance if there are high requirements regarding noise emission. DRn is a powerful, dynamic and cost-effective solution for large drive power from approx. 4 kW (5 hp). It uses the frequency converter to detect the condition of the motor and the pump and sets the perfect speed. By unloading the motor in stand-by operation, high overload capacity is achieved. In combination with DRG pumps, you can also realize several pressure ratings.



FcP 5020 is based on the robust frequency converter EFC 5610 and has been optimized for small power units. Using the quiet internal gear pump PGF or PGH, lower operating noises can also be achieved without encapsulation. Sensors like level switches, oil temperature and filter monitoring of the power unit can be directly connected at the frequency converter and evaluated. This reduces the necessary cabling and accelerates the installation of the power unit in the machine.

For extended system functionalities, the FcP 7020 systems on IndraDrive basis are available, as well.



DRn has been designed for pressure control systems and is a symbiosis of variable-speed drive and variable displacement pump. In partial load operation, the pump is able to reduce the torque at the motor by reduction of the swivel angle and the drive reduces the speed so that the energy consumption is optimized. The variable displacement pump moreover makes sure that no braking resistance is required and that thus, the energy efficiency and the installation space can be optimized. As standard pumps DR or DRG controllers are used, the system is perfectly suited for retrofitting.

FcP 5020

Features

- ▶ Preferred system for power output from 0.25 to 18.5 kW (0.3 to 25 hp). Apart from that, FcP can be used if DRn cannot be used, e.g. for noise reasons.
- ▶ Particularly low operating noise thanks to the use of internal gear pumps
- ▶ Apart from the Sytronix functionality, FcP 5020 on the basis of the frequency converter EFC 5610 offers monitoring of the sensors at the power unit
- ▶ 1-quadrant operation
- ▶ Integrated pump guard function
- ▶ Safety technology STO (Safe Torque Off)

Components

- ▶ Pre-configured motor-pump combinations consisting of
 - MOT-FC motor, forced- or self-ventilated
 - Pump of type PGF or PGH
 - Standard coupling elements
- ▶ Frequency converter EFC 5610

Applications

- ▶ Suitable for use in open hydraulic circuits for central pressure supply in power units with multiple axes: i.e. pressure control systems. FcP is an energy-saving solution and can reduce hydraulic energy consumption by 30 to 70 %, depending on the duty cycle. Typically a smaller displacement pump can be used and cooling requirements are reduced for the same hydraulic performance.
- ▶ In pressure control systems as of approx. 4 kW (5hp), DRn is recommended. In case of requirements such as a particularly low-noise power unit, the use of FcP may
- ▶ also be reasonable with higher outputs.

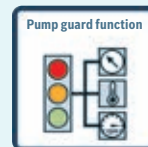

Pump guard function

A pump guard function has been integrated in all FcP systems extending the life cycle and preventing machine standstill

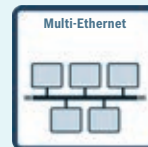

Multi-Ethernet

Support of standard communication protocols provides flexibility for the integration into a multitude of system topologies

FcP 5020 with PGF, MOT-FC self-ventilated

PRODUCT SELECTION GUIDE FOR SYTRONIX FcP 5020 WITH PGF

Pumps $n_{max} = 3600$ rpm						Motors MOT-FC IC 411 / TEFC (self-ventilated)													
Type	Size	p_{cont} [bar]	p_{max} [bar]	Q_{pRMS}^{***} [l/min]	Q_{max} [l/min]	P_{nom} [kW] [hp]													
						0.25	0.37	0.55	0.75	1.10	1.5	2.2	3	4	5.5	7.5	11	15	
						0.34	0.50	0.74	1.01	1.47	2.01	2.95	4.02	5.36	7.37	10.05	14.75	20.11	
						4200	4200	4200	4200	4200	4200	4000	4000	4000	4000	4000	3800	3800	
						p_{RMS}^* [bar]													
						n_{max} [rpm]													
PGF1	1.7	180	210	3.6	6	44	65	96	129	180									
	2.2	210	250	4.6	7	34	50	74	100	148	198	210							
	2.8	210	250	5.9	10	27	39	58	79	116	156	210							
	3.2	210	250	6.7	11	23	34	51	69	102	136	199	210						
	4.1	210	250	8.6	14	18	27	40	54	79	106	156	210						
	5	180	210	10.5	18		22	33	44	65	87	128	176	180					
PGF2	006	210	250	14	23		17	25	34	50	67	98	135	176	210				
	008	210	250	17	29			20	27	40	53	78	107	139	193	210			
	011	210	250	23	39				20	30	40	58	80	104	144	196	210		
	013	210	250	28	47				17	24	33	48	66	86	119	162	210		
	016	210	250	34	57					20	27	40	55	71	99	135	198	210	
	019	210	250	40	68					17	23	34	47	61	84	114	168	210	
	022**	180	210	46	66						20	29	40	52	72	98	144	180	
Pump Drive						K [%]													
						167	118												
						295	209	148	124										
								258	216	148	118								
										207	165	122							
												161	121						
													159	123					
														161	115				
															153	112			
																162	116		
																	154	116	

* RMS pressure without consideration of the efficiency
 ** 3,000 rpm
 *** QpRMS is calculated with a speed of 2,100 rpm

Detailed component information

- ▶ Motors: see "Motors" starting on page 53
- ▶ Pumps: Data sheet RE 10213
- ▶ Controllers: Catalog R999000430

Detailed explanation of the tables on page 9

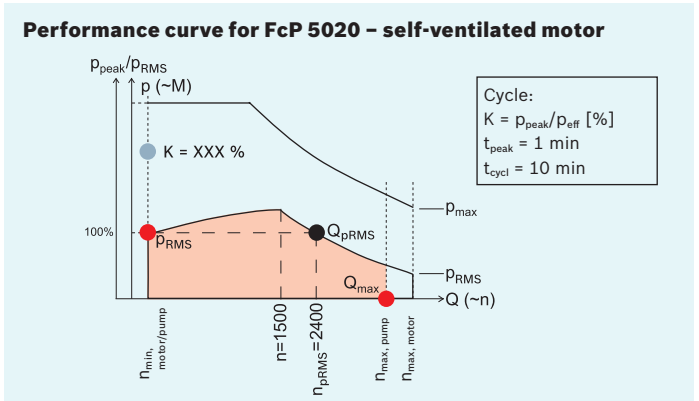

FcP 5020 with PGF, MOT-FC forced-ventilated

PRODUCT SELECTION GUIDE FOR SYTRONIX FcP 5020 WITH PGF

Pumps n _{max} = 3600 U/min						Motors MOT-FC IC 416 / TEBC (forced-ventilated)																
Type	Size	p _{cont} [bar]	p _{max} [bar]	Q _{pRMS} *** [l/min]	Q _{max} [l/min]	p _{RMS} * [bar]								P _{nom} [kW]	P _{nom} [hp]							
PGF1	2,8	210	250	4,1	10	210								1.5	2.2	3	4	5.5	7.5	11	15	
	3,2	210	250	4,6	11	194	210								2.01	2.95	4.02	5.36	7.37	10.05	14.75	20.11
	4,1	210	250	5,9	14	152	210								4200	4000	4000	4000	4000	4000	3800	3800
	5	180	210	7,3	18	124	180								n _{max} [rpm]							
PGF2	006	210	250	9,4	23	96	140	193	210													
	008	210	250	12	29	76	111	153	199	210												
	011	210	250	16	39	57	83	114	149	206	210											
	013	210	250	19	47	47	69	94	123	170	210											
	016	210	250	23	57	39	57	79	102	141	192	210										
	019	210	250	27	68	33	48	66	86	120	163	210										
	022**	180	210	32	66	28	41	57	74	103	140	180										
	Pump Drive						K [%]															
	EFC5610						1K50	118														
							2K20	165														
3K00							122															
4K00							161															
5K50							121															
7K50							159															
11K0							123															
15K0							161															
							115															
							153															
	112																					
	162																					
	116																					
	154																					
	116																					

* RMS pressure without consideration of the efficiency
 ** 3,000 rpm
 *** QpRMS is calculated with a speed of 1,450 rpm

Detailed component information

- ▶ Motors: see "Motors" starting on page 53
- ▶ Pumps: Data sheet RE 10213
- ▶ Controllers: Catalog R999000430

Detailed explanation of the tables on page 9

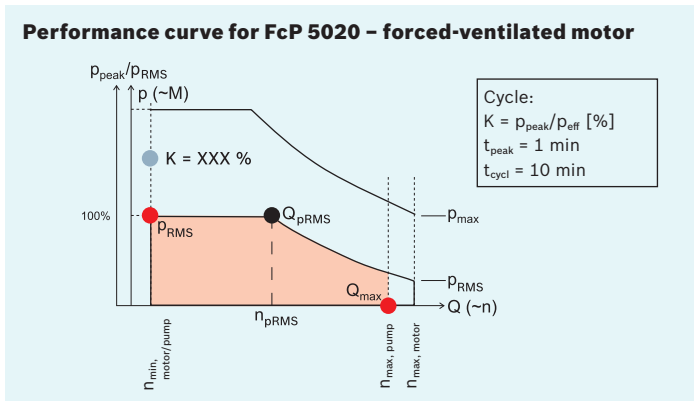

DRn 5020

Features

- ▶ Nominal power up to 160 kW (200 hp)
- ▶ Easy and powerful solution for energy-saving pressure control systems
- ▶ 1-quadrant operation
- ▶ Safety technology STO (Safe Torque Off)
- ▶ Motor-auto tuning

Components

- ▶ Pre-configured motor-pump combinations consisting of
 - MOT-FC motor, self-ventilated
 - Pump of type A10VZO-DR or A4VSO-DR
 - Standard coupling elements
- ▶ Frequency converter Rexroth EFC 5610

Applications

- ▶ The DRn system is basically used for pressure control systems with higher performance, e.g. for press lines, metallurgy, wood working or central hydraulics for several machines



Hydraulic Gear

The use of axial piston pumps with stepless adjustment enables downsizing of the drive system

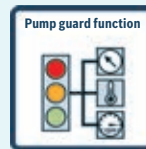

Pumpenschutzfunktion

A unique pump guard function has been integrated in all DRn systems extending the life cycle and preventing machine standstill

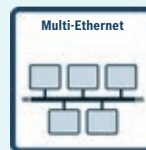

Multi-Ethernet

Support of standard communication protocols provides flexibility for the integration into a multitude of system topologies



Retrofit

Existing pump systems can be converted for energy efficient and noise-optimized operation with minimum effort

DRn 5020 with A4VSO

PRODUCT SELECTION GUIDE FOR SYTRONIX DRn 5020 WITH A4VSO

Pumps							Motors																	
Type	Size	p _{cont} [bar]	p _{max} [bar]	n _{max} [U/min]	Q _{pRMS} ** [l/min]	Q _{max} [l/min]	MOT-FC IC 411 / TEFC (self-ventilated)																	
							p _{RMS} * [bar]									P _{nom} [kW]				P _m [hp]				
A4VSO	040	350	400	2600	58	104	188	225	305	350	18.5	22	30	37	45	55	75	90	110	132	160			
	071	350	400	2200	103	156	106	127	172	211	24.8	29.5	40.2	49.6	60.32	73.7	100.5	120.6	147.5	176.9	214.5			
	125	350	400	1800	181	225	60	72	98	120	3800	3800	3800	2800	2800	2800	2800	2800	2500	2500	2500			
	180	350	400	1800	261	324			68	83														
	250	350	400	1900	363	475				60														
	355	370	400	1700	515	603																		
	500	350	400	1500	725	750																		
							n _{max} [rpm]																	
							188	225	305	350														
							106	127	172	211	257	313	350											
							60	72	98	120	146	178	243	292	350									
											101	124	169	202	246	297	350							
											73	89	121	146	177	214	259							
											51	63	85	103	125	150	182							
														61	73	89	107	129						
							K [%]																	
Pump Drive							18K5	115																
							22K0	132	113															
							30K0	179	152	113														
							37K0		184	136	110													
							45K0			165	133	110												
							55K0				161	133	109											
							75K0					181	148	113										
							90K0						178	135	113									
							110K0							163	136	111								
							132K0								162	132	111							
							160K0									159	133	111						

* RMS pressure without consideration of the efficiency

** Q_{pRMS} is calculated with a speed of 1,450 rpm. With lower pump speed, however, the maximum speed serves as calculation basis

Detailed component information

Motors: see "Motors" starting on page 53

Pumps: Data sheet RE 9250

Pump Drive: Catalogs R999000019, R999000242

Detailed explanation of the tables on page 9

Performance curve for DRn 5020 – self-ventilated motor

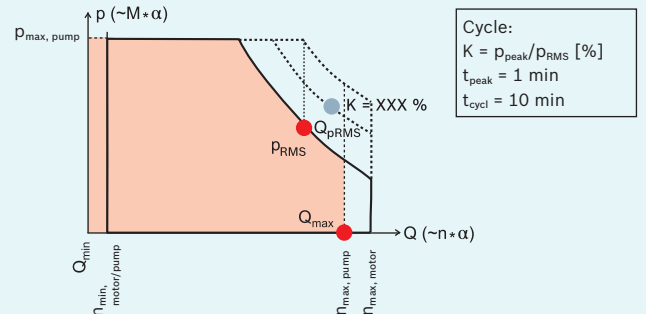

Sytronix for p/Q control SY(H)DFEn

In many systems and machines in the higher performance range, p/Q control systems are used in order to transform the installed motor power as required, e.g. in fast forward movements or in powerful pressing processes. In this connection, the variable displacement pump takes over the function of a gear. SY(H)DFEn is a variable-speed system in which the energy-saving variable displacement pumps are combined with a variable-speed drive.

Sytronix SY(H)DFEn systems comprise one electro-hydraulically controlled axial piston pump with a speed-variable asynchronous motor.

Pump drives SY(H)DFEn are based on the proven SY(H)DFE system for pressure and flow control of pumps.

Using industry standard inverter duty motors, up to 315 kW (420 hp), results in a higher price/performance ratio and higher performance capabilities.



p/Q control systems Sytronix SY(H)DFEn

Sytronix SY(H)DFEn systems

- ▶ Reduction of installed power by speed and flow control
- ▶ Easy retrofit for power units with variable displacement pumps (refer to RE30637)
- ▶ High performance capability
- ▶ Support of multi-actuator systems

Function

A SY(H)DFEn type system utilizes an electro-hydraulically controlled axial piston pump to control the pump's frequency converter drive. Identical mechanical interfaces permit cost-effective retrofitting, e.g. of a SY(H)DFEn – as a replacement for a SY(H)DFEE/SY(H)DFEC by simply exchanging the integrated pump valve electronics.

The control system is available for A10 and A4 pump types and can thus be used for a wide variety of applications. When using the **„teach-in“ version**, the machine cycle pressure and flow profile is stored in the SY(H)DFEn control electronics. This allows the SY(H)DFEn system to accelerate the electric motor according to the required flow.

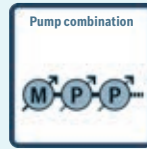

Pump combination

The use of double pump systems enables downsizing of the drive system while cooling and filtration functions in the hydraulic circuit can be transferred

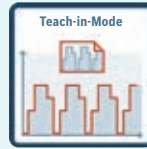

Teach-in mode

for cyclic applications (incl. relearning function)



Real-time mode

for acyclic applications

In systems operating without a predictable operating cycle, such as applications in the wood and metallurgy area, a **„Real-time mode“** can be used. The SY(H)DFEn controller calculates an optimal combination of motor speed and pump swivel angle to maximize energy savings.

SY(H)DFEn block diagram

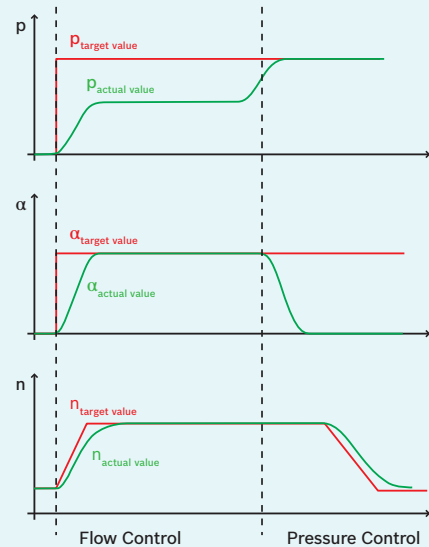
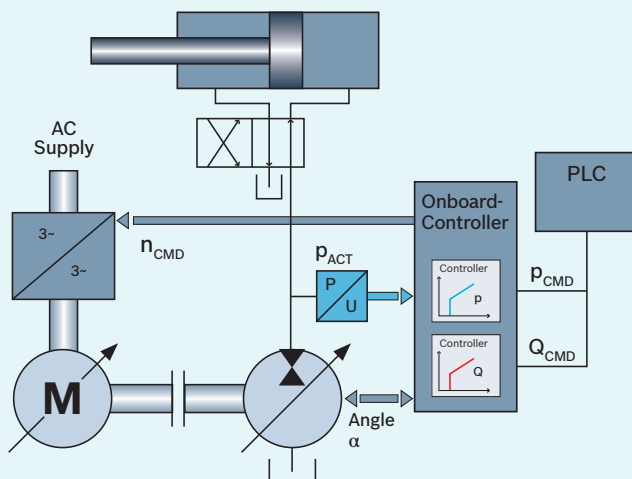

SY(H)DFEn

Features

- ▶ Nominal power up to 315 kW (420 hp)
- ▶ Suitable for pressure and flow control in open hydraulic systems with one or more hydraulic actuators
- ▶ 2-quadrant operation

Components

- ▶ Pre-configured motor-pump system combinations consisting of
 - MOT-FC motor, self-ventilated
 - Pump system of type SYDFEn, SYHDFEn
 - Standard coupling elements
- ▶ EFC 5610, IndraDrive (HCS) controller with basis or advanced control part

Applications

Covering a power range up to 315 kW (420 hp), the systems are particularly suited for use in harsh industrial environments, such as press lines, plastics machines, wood and metal industries.

Thanks to different through-drive versions, several pumps can be connected. In this way, users can combine the pumps from the broad Rexroth portfolio in almost any way. This allows for direct energy coupling and mechanical feedback via the pump shaft. No drive system with power recovery is required.

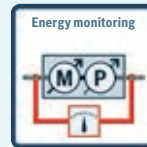

Energy monitoring

Enhanced energy monitoring functions lead to energy-optimized systems



Power limitation

Power limitation is application-specifically adjustable

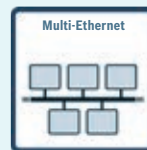

Multi-Ethernet

Support of standard communication protocols provides flexibility for the integration into a multitude of system topologies

SYDFEn (A10VSO)

PRODUCT SELECTION GUIDE FOR SYTRONIX SYDFEn (A10VSO)

Pumps							Motors															
Type	Size	p _{cont} [bar]	p _{max} [bar]	n _{max} [U/min]	Q _{pRMSf} ** [l/min]	Q _{max} [l/min]	MOT-FC IC 411 / TEFC (self-ventilated)															
							P _{nom} [kW] [hp]															
							4	5.5	7.5	11	15	18.5	22	30	37	45	55	75	90	110	132	
							5.4	7.4	10.1	14.8	20.1	24.8	29.5	40.2	49.6	60.3	73.8	100.5	120.6	147.5	176.9	
							4000	4000	4000	3800	3800	3800	3800	3800	2800	2800	2800	2800	2800	2800	2500	2500
							p _{RMS} * [bar]															
																						n _{max} [rpm]
A10VSO	018	280	315	3300	26	59	91	126	171	251	280											
	028	280	315	3000	41	84	58	81	110	162	220	269	280									
	045	280	315	3000	65	135	36	50	68	101	137	168	200	271	280							
	071	280	315	2550	103	181	23	32	43	64	87	106	126	171	210	256	280					
	100	280	315	2300	145	230		23	31	45	62	75	90	122	150	182	222	280				
	140	280	315	2200	203	308			22	32	44	54	64	87	107	130	159	217	260	280		
	180	280	315	1800	261	324				25	34	42	50	68	83	101	124	169	202	246	280	

				K [%]																					
Pump Drive	SYDFEn 5020	EFC5610	4K00	123																					
			5K50	161	115																				
			7K50		153	112																			
			11K0			162	116																		
			15K0				154	116																	
			18K5					187	140	115															
			22K0						161	132	113														
			30K0							179	152	113													
			37K0								184	136	110												
			45K0									165	133	110											
			55K0										161	133	109										
			75K0											181	148	113									
			90K0												178	135	113								
			110K													163	136	111							
132K														162	132	111									
160K															159	133									
SYDFEn 7020	HCS01.1E	-W0028	146	105																					
		-W0054		191	140	100																			
	HCS02.1E	-W0070			187	133	100																		
		-W0100					161	132	113																
	HCS03.1E	-W0150						183	135	109															
		-W0210							176	142	117														
		-W0280								179	146	112													
		-W0350									167	127	106												
												154	128	105											

* RMS pressure without consideration of the efficiency
 ** QpRMS is calculated with a speed of 1,450 rpm

Detailed component information
 Motors: see "Motors" starting on page 53
 Pumps: Data sheet RE 30030 (size 18 and 28) and RE 30630 (size 45 to 180)
 Pump drive: Catalogs R999000019, R999000242

Detailed explanation of the tables on page 9

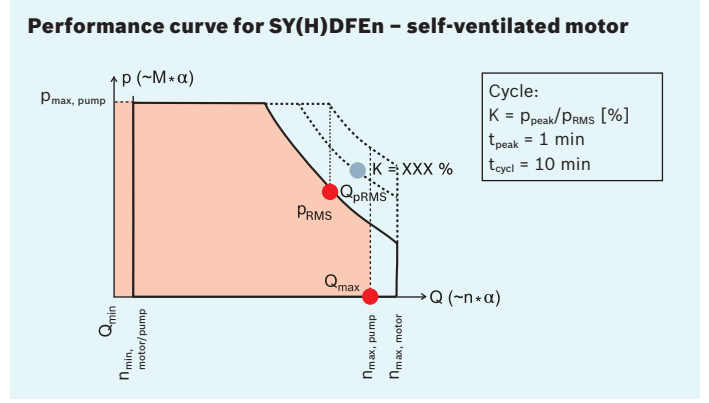

SY(H)DFEn (A4VSO)

PRODUCT SELECTION GUIDE FOR SYTRONIX SY(H)DFEN (A4VSO)

Pumps							Motors																			
Type	Size	p _{cont} [bar]	p _{max} [bar]	n _{max} [U/min]	Q _{pRMS} ** [l/min]	Q _{max} [l/min]	MOT-FC IC 411 / TEFC (self-ventilated)																			
							P _{nom} [kW] [hp]																			
							p _{RMS} * [bar]																			
							n _{max} [rpm]																			
A4VSO	125	350	400	1800	181	225	18.5	22	30	37	45	55	75	90	110	132	160	200	250	315						
	180	350	400	1800	261	324	24.8	29.5	40.2	49.6	60.3	73.7	101	121	147	177	214	268	335	422						
	250	350	400	1900	363	475	3800	3800	3800	2800	2800	2800	2800	2800	2800	2500	2500	2500	2500	2200	2200					
	355	370	400	1700	515	603																				
							60	72	98	120	146	178	243	292	350											
									68	83	101	124	169	202	246	297	350									
										60	73	89	121	146	177	214	259	323	350							
											51	63	85	103	125	150	182	227	285	358						
							K [%]																			
Pump Drive	DFEEn 5020	EFC5610	18K5	115																						
			22K0	132	113																					
			30K0	179	152	113																				
			37K0		184	136	110																			
			45K0			165	133	110																		
	55K0				161	133	119																			
	75K0					181	148	113																		
	90K0						178	135	113																	
	110K							163	136	111																
	132K								195	162	132	111														
160K									159	133	111															
DFEEn 7020	HCS03.1E	-W0070	132	113																						
		-W0100		183	135	109																				
		-W0150			176	142	117																			
		-W0210				179	146	112																		
		-W0280					167	127	106																	
-W0350						154	128	105																		
IndraDrive ML HMU05	-W0430						196	160	134	112																
	-W0510								172	144	115															
	-W0660									179	144	116														
	-W0820										181	146	166													
	-W1040											183	145													

* RMS pressure without consideration of the efficiency
 ** QpRMS is calculated with a speed of 1,450 rpm

Detailed component information

Motors: see "Motors" starting on page 53
 Pumps: Data sheet RE 30035
 Pump Drive: Kataloge R999000019, R999000242

Detailed explanation of the tables on page 9

Performance curve for SY(H)DFEn – self-ventilated motor

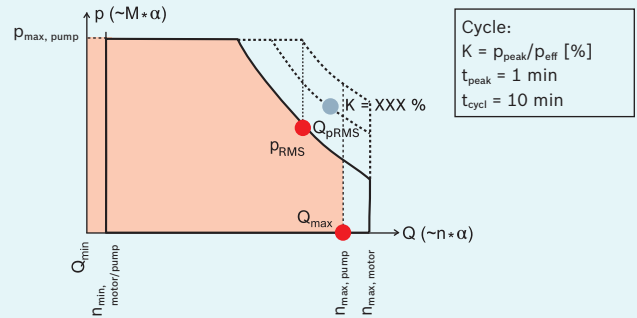

Sytronix for p/Q, F/x axis control SvP 7020*

The new control section generation of SvP 7020 opens up new possibilities for Sytronix such as Industry 4.0, Open Core Engineering and remote maintenance. Utilize the advantages of these customized, compact solutions which can be easily installed and commissioned: In this way, you not only reduce noise in the smallest spaces but also achieve higher dynamics with up to 80 % energy saving.

SvP-System

Sytronix type SvP (**s**ervo-**v**ariable **p**ump drive) 7020 drive systems consist of a motor-pump unit driven by a synchronous servo motor with permanent magnet and servo control. In the Sytronix product family, Sytronix SvP offers the highest dynamic performance and closed-loop accuracy as well as the broadest range of functionalities: from pressure control and alternating pressure/flow control to the alternating position and force control.

The SvP 7020 system can be configured for required communication interfaces by exchanging the CSH control part. The command and actual values for pressure, flow and position can be adjusted and monitored by a superior machine control using either an analog interface or an industry standard bus interface, thus providing an easy and flexible integration into machine control systems.

Functionality

Using an internal gear pump of type PGH, the required flow is directly regulated by the motor speed. The pumps are optimized for variable-speed operation and achieve a high overall efficiency due to low leakage, and operate with minimum noise development.

In operation, sensors measure pressure, actuator position** and the servo motor speed. These values are used by the servo control. The command values which are set by the machine control are compared by the IndraDrive according to the system requirements with the setting of the pump drive speed.

Decisive advantages of the SvP system:

- ▶ High efficiency servo motors with versions for a standardized and direct assembly of pumps
- ▶ High dynamics and closed-loop accuracy
- ▶ Broad range of control functions

SvP block diagram

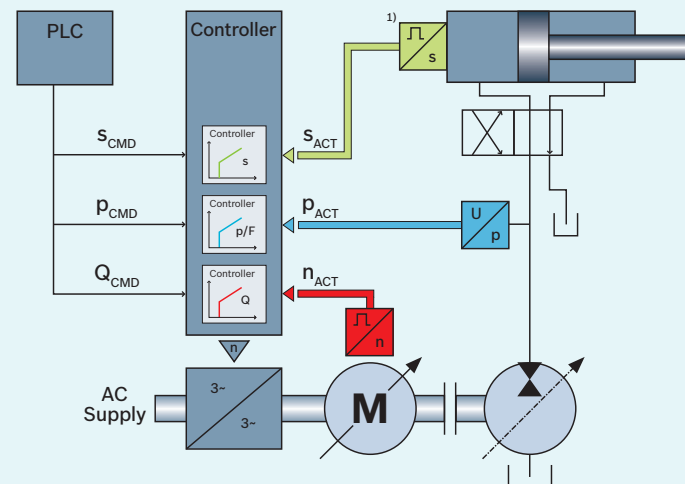

* p/Q: Pressure-/Flow rate control, f/X: Force-/Position-control

** Only for systems with Position Force Control (PFC)

SvP 7020

Features

- ▶ Nominal power up to 80 kW (100 hp)
- ▶ Maximum system pressure with PGH pump up to 350 bar, with A10 up to 315 bar
- ▶ Suitable for axis control in open and closed hydraulic systems
- ▶ 2- or 4-quadrant operation

Components

- ▶ Motor-pump unit MPA01 or MPA02 (direct coupling) or motor-pump assemblies with standard coupling consisting of
 - MSK or MS2N motor, air- or liquid-cooled
 - Internal gear pump type PGH
 - Standard coupling elements
- ▶ IndraDrive (HCS or HMS) controller with basis or advanced control part
- ▶ Individually configured motor-pump units of servo motors and pumps such as PGH, A10, A4

Application

- ▶ The SvP 7020 offers performance up to 80 kW (100 hp) and is ideal in the following fields of application:
 - Injection molding machines
 - Die casting machines
 - Press lines
- ▶ The controller is optimized for Sytronix applications and compensates for the characteristics of hydraulic systems to provide optimal dynamics and accuracy

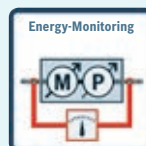

Energy monitoring

Enhanced energy monitoring functions lead to energy-optimized systems

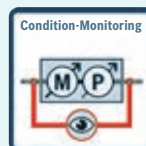

Condition monitoring

Connection of condition monitoring and predictive maintenance ODIN

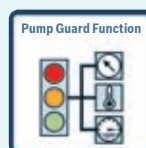

Pump guard function

A unique pump guard function has been integrated in all SvP systems extending the life cycle and preventing machine standstill

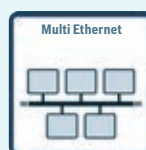

Multi Ethernet

Support of standard communication protocols provides flexibility for the integration into a multitude of system topologies

SvP 7020 with PGH, MS2N/MSK forced-ventilated

PRODUCT SELECTION GUIDE FOR SYTRONIX SvP 7020 WITH PGH

Pumps n _{max} = 3000 rpm						Motors (forced-ventilated)											
Type	Size	p _{cont} [bar]	p _{max} [bar]	Q _{max} [l/min]	Vg [ccm]	MS2N07			MS2N10				MSK133				
						COBN	DOBN	EOBN	COBN	DOBN	EOBN	FOBN	B-0202	C-0202	D-0202	E-0202	
						19.8	35.5	49.5	43.2	82.4	119.0	142.0	152.0	204.0	263.0	293.0	
						38.8	79.7	119.5	76.8	155.0	234.0	287.0	320.0	425.0	520.0	630.7	
						p_{RMS}* [bar]											
						M _{cont} [Nm] M _{max} [Nm]											
PGH2	005	315	350	15	5.2	239	315										
	006	315	350	18	6.5	191	315										
	008	315	350	24	8.2	125	272	315									
PGH3	011	315	350	33	11.0	113	203	283	247	315							
	013	315	350	39	13.3	94	168	234	204	315							
	016	315	350	48	16.0	78	139	194	170	315							
PGH4	020	315	350	60	20.1	62	111	155	135	258	315						
	025	315	350	75	25.3	49	88	123	107	205	296	315					
	032	315	350	100	32.7	38	68	95	83	158	229	273	292	315			
	040	315	350	120	40.1	31	56	78	68	129	186	222	238	315			
	050	250	310	150	50.7	25	44	61	54	102	147	176	188	250			
	063	210	250	190	65.5	19	34	47	41	79	114	136	146	196	210		
PGH5	063	315	350	190	64.7				42	80	116	138	148	198	255	285	
	080	315	350	240	81.4				33	64	92	110	117	157	203	226	
	100	315	350	300	100.2				27	52	75	89	95	128	165	184	
	125	315	350	375	125.3				22	41	60	71	76	102	132	147	
	160	210	260	480	162.8				17	32	46	55	59	79	102	113	
	200	170	210	600	200.4					26	37	45	48	64	82	92	
	250	135	170	750	250.5					21	30	36	38	51	66	73	

						K [%]													
Pump Drive	SvP 7020 Compact	HCS01.1E	-W0018	18.0	7.6	114													
			-W0028	28.5	11.5	166													
			-W0054	54.0	21.0	196	176	135	130										
		HCS02.1E	-W0028	28.5	11.5	172	109												
			-W0054	54.0	20.6		174	133	128										
			-W0070	70.8	28.0		222	174	158	99									
	SvP 7020 Modular	HMS01.1N	-W0070	70.0	45.0					225	224	163	127	102	103				
			-W0100	100.0	73.0							241	161	134	96	138	111	91	
			-W0150	150.0	95.0								172	177	134	188	155	128	115
			-W0210	210.0	145.0									197	185	211	208	175	166
			-W0280	280.0	165.0										202	211	208	191	186
			-W0350	350.0	200.0													191	213
							148												
						196	155	118	116										
							225	187	163	106									
								210		119	95								
								241		165	138	100	143	115					
										172	180	138	193	159	132	119			
												184		208	174	165			
												197			198	191			

* RMS pressure without consideration of the efficiency

Detailed component information

Motors: see "Motors" starting on page 53
 Pumps: Data sheet RE 10227
 Pump drive: Catalog R999000019

Detailed explanation of the tables on page 9

Performance curve for SvP 7020 – forced-ventilated motor

Cycle:
 $K = p_{peak}/p_{RMS} [%]$
 $t_{peak} = 2 \text{ s}$
 $t_{cycl} = 20 \text{ s}$

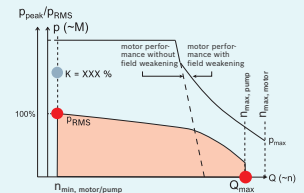

Explanation at page 10

SvP 7020 with A10VZO MS2N/ MSK forced-ventilated

PRODUCT SELECTION GUIDE FOR SYTRONIX SvP 7020 WITH A10VZO

Pumps $n_{max} = 3000 \text{ rpm}$						Motors (forced-ventilated)												
Type	Size	P_{cont} [bar]	P_{max} [bar]	Q_{max} [l/min]	V_g [ccm]	MS2N07			MS2N10				MSK133					
						COBN	DOBN	EOBN	COBN	DOBN	EOBN	FOBN	B-0202	C-0202	D-0202	E-0202		
						19.8	35.5	49.5	43.2	82.4	119.0	142.0	152.0	204.0	263.0	293.0		
						38.8	79.7	119.5	76.8	155.0	234.0	287.0	320.0	425.0	520.0	630.7		
						$P_{RMS}^* \text{ [bar]}$												
						$M_{cont} \text{ [Nm]}$ $M_{max} \text{ [Nm]}$												
A10VZO	010	250	250	900	10.5	118	212											
	018	315	280	1039	18.0	69	124	173	151	288								
	028	315	280	945	28.0	44	80	111	97	185	267							
	045	315	280	945	45.0	28	50	69	60	115	166	198	212	285				
	071	280	280	714	71.1	17	31	44	38	73	105	125	134	180	232	259		
	100	280	280	644	100.0		22	31	27	52	75	89	96	128	165	184		
	140	280	280	616	140.0		16	22	19	37	53	64	68	92	118	131		
180	280	280	504	180.0				17	15	29	42	50	53	71	92	102		
						$K \text{ [%]}$												
Pump Drive	SvP 7020 Compact	HCS01.1E	-W0018	18.0	7.6	114												
			-W0028	28.5	11.5	166												
			-W0054	54.0	21.0	196	176	135	130									
		HCS02.1E	-W0028	28.5	11.5	172	109											
			-W0054	54.0	20.6		174	133	128									
			-W0070	70.8	28.0		222	174	158	99								
	HCS03.1E	-W0070	70.0	45.0		225	224	163	127	102	103							
		-W0100	100.0	73.0			241		161	134	96	138	111	91				
		-W0150	150.0	95.0					172	177	134	188	155	128	115			
		-W0210	210.0	145.0						197	185	211	208	175	166			
		-W0280	280.0	165.0							202			191	186			
	-W0350	350.0	200.0										198	213				
	SvP 7020 Modular	HMS01.1N	-W0020	20.0	12.1	148												
			-W0036	36.0	21.3	196	155	118	116									
-W0054			54.0	35.0		225	187	163	106									
-W0070			70.7	42.4			210		119	95								
-W0110			110.0	68.5			241		165	138	100	143	115					
-W0150			150.0	99.7					172	180	138	193	159	132	119			
-W0210			210.0	150.7							184		208	174	165			
-W0300			300.0	150.1							197			198	191			

* RMS pressure without consideration of the efficiency

Detailed component information

Motors: see "Motors" starting on page 53

Pumps: Data sheet RE 10227

Pump drive: Catalog R999000019

Detailed explanation of the tables on page 9

Performance curve for SvP 7020 – forced-ventilated motor

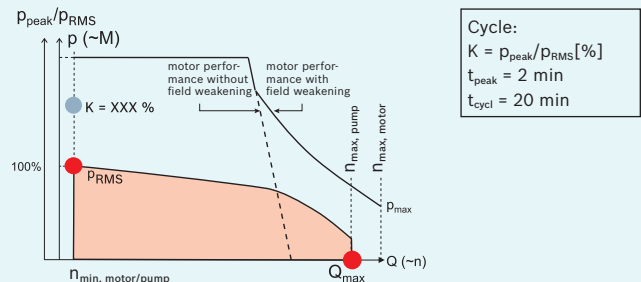

SvP 7020 with PGH, MS2N/ MSK liquid-cooled

PRODUCT SELECTION GUIDE FOR SYTRONIX SvP 7020 WITH PGH

Pumps n _{max} = 3000 rpm						Motors (liquid-cooled)												
Type	Size	P _{cont} [bar]	P _{max} [bar]	Q _{max} [l/min]	V _g [ccm]	MS2N07			MS2N10				MSK133					
						COBN	DOBN	E0BN	COBN	DOBN	E0BN	FOEN	FOCN	B-0203	C-0203	D-0203	E-0203	
						p _{RMS} * [bar]								M _{cont} [Nm]		M _{max} [Nm]		
PGH2	005	315	350	15	5.2	315												
	006	315	350	18	6.5	257 315												
	008	315	350	24	8.2	204 315												
PGH3	011	315	350	33	11.0	152 314 315 295 315												
	013	315	350	39	13.3	126 260 315 244 315												
	016	315	350	48	16.0	104 216 315 203 315												
PGH4	020	315	350	60	20.1	83 172 259 162 315												
	025	315	350	75	25.3	66 137 206 128 267 315												
	032	315	350	100	32.7	51 106 159 99 207 311 261 315 311 315												
	040	315	350	120	40.1	42 86 130 81 168 254 213 284 254 315												
	050	250	250	150	50.7	33 68 103 64 133 201 169 224 201 250												
	063	210	250	190	65.5	26 53 80 50 103 155 130 174 155 210												
PGH5	063	315	350	190	64.7	50 104 157 132 176 157 226 282 315												
	080	315	350	240	81.4	40 83 125 105 140 125 179 224 264												
	100	315	350	300	100.2	32 67 102 85 113 102 146 182 214												
	125	315	350	375	125.3	26 54 81 68 91 81 117 145 171												
	160	210	260	480	162.8	20 41 63 52 70 63 90 112 132												
	200	170	210	600	200.4	16 34 51 43 57 51 73 91 107												
250	135	170	750	250.5	27 41 34 45 41 58 73 86													
						K [%]												
Pump Drive	SvP 7020 Compact	HCS01.1E	-W0028	28.5	11.5	122												
			-W0054	54.0	21.0	146 113 108												
		HCS02.1E	-W0028	28.5	11.5	127												
			-W0054	54.0	20.6	112 107												
		SvP 7020 Modular	HMS01.1N	-W0070	70.0	45.0	143 105 132											
				-W0100	100.0	73.0	145 134 136 97											
	-W0150			150.0	95.0	123 98 100 96												
	-W0210			210.0	145.0	132 130 139 106 176 136 116 98												
	-W0280			280.0	165.0	144 192 145 198 183 159 142												
	-W0350			350.0	200.0	211 159 165 153												
	SvP 7020 Modular	HMS01.1N	-W0020	20.0	12.1	108												
			-W0036	36.0	21.3	146 100 97												
-W0054			54.0	35.0	145 112 136													
-W0070			70.7	42.4	91													
-W0110			110.0	68.5	127 102 104 134 101													
-W0150			150.0	99.7	132 132 143 109 181 140 119 102													
-W0210	210.0	150.7	192 145 145 183 158 141															
-W0300	300.0	150.1	155 179 164															

* RMS pressure without consideration of the efficiency

Detailed component information
 Motors: see "Motors" starting on page 53
 Pumps: Data sheet RE 10227
 Pump drive: Catalog R999000019

Detailed explanation of the tables on page 9

Performance curve for SvP 7020 – liquid-cooled motor

Cycle:
 $K = p_{peak}/p_{RMS} [%]$
 $t_{peak} = 2 \text{ s}$
 $t_{cycl} = 20 \text{ s}$

Explanation at page 10

SvP 7020 with A10VZO, MS2N/ MSK liquid-cooled

PRODUCT SELECTION GUIDE FOR SYTRONIX SvP 7020 WITH A10VZO

Pumps $n_{max} = 3000 \text{ rpm}$							Motors (liquid-cooled)															
Type	Size	p_{cont} [bar]	p_{max} [bar]	n_{max} [1/min]	Q_{max} [l/min]	V_g [ccm]	MS2N07			MS2N10				MSK133								
							COBN	DOBN	EOBN	COBN	DOBN	EOBN	FOBN	B-0202	C-0202	D-0202	E-0202					
A10VZO	010	250	250	3600	37	10.5	159															
	018	315	280	3300	59	18.0	93	192	290	180												
	028	315	280	3000	84	28.0	60	123	186	116	241											
	045	315	280	3000	135	45.0	37	77	116	72	150	226	253	226								
	071	280	280	2550	181	71.1	24	49	73	46	95	143	160	143	205	256						
	100	280	280	2300	230	100.0	17	35	52	32	68	102	114	102	146	182	215					
	140	280	280	2200	308	140.0		25	37	23	48	73	81	73	104	130	153					
	180	280	280	1800	324	180.0		19	29	18	38	57	63	57	81	101	119					
							$p_{RMS}^* \text{ [bar]}$															
												$M_{cont} \text{ [Nm]}$		$M_{max} \text{ [Nm]}$								
Pump Drive							K [%]															
SvP 7020 Compact	HCS01.1E	-W0028	28.5	11.5	122																	
		-W0054	54.0	21.0	146	113																
		-W0028	28.5	11.5	127																	
		-W0054	54.0	20.6		112																
		-W0070	70.8	28.0		143	105															
		-W0070	70.0	45.0		145	134	136														
	HCS02.1E	-W0100	100.0	73.0							97				96							
		-W0150	150.0	95.0							123	98			129	97						
		-W0210	210.0	145.0							132	130	106		176	136	116	98				
		-W0280	280.0	165.0								144	145	159	198	183	159	142				
		-W0350	350.0	200.0																		
		-W0210	210.0	150.7																		
		-W0280	280.0	165.0																		
		-W0350	350.0	200.0																		
SvP 7020 Modular	HMS01.1N	-W0020	20.0	12.1	108																	
		-W0036	36.0	21.3	146	100																
		-W0054	54.0	35.0		145																
		-W0070	70.7	42.4																		
		-W0110	110.0	68.5																		
		-W0150	150.0	99.7																		
		-W0210	210.0	150.7																		
		-W0280	280.0	165.0																		
		-W0300	300.0	150.1																		

* RMS pressure without consideration of the efficiency

Detailed component information

Motors: see "Motors" starting on page 53
 Pumps: Data sheet RE 10227
 Pump drive: Catalog R999000019

Detailed explanation of the tables on page 9

Performance curve for SvP 7020 – liquid-cooled motor

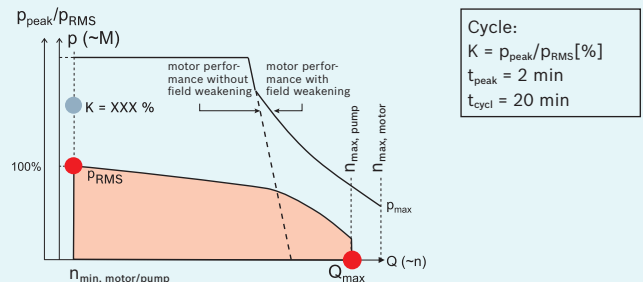

Sytronix for p/Q, F/x axis control SvP 5020*

The inexpensive pump control EFC 5610 of the SvP 5020 opens up new possibilities for Sytronix such as Industry 4.0 and the connection of condition monitoring and predictive maintenance ODiN. Utilize the advantages of these customized, compact solutions which can be easily installed and commissioned: In this way, you not only reduce noise in the smallest spaces but also achieve higher dynamics with up to 80 % energy saving.

SvP system

Sytronix type SvP (**s**ervo-**v**ariable **p**ump drive) 5020 drive systems consist of a motor-pump unit driven by a synchronous servo motor with permanent magnet and servo control. In the Sytronix product family, Sytronix SvP 5020 offers a middle dynamic performance and closed-loop accuracy as well as a wide range of functionalities: from pressure control to alternating pressure/flow control.

The SvP 5020 system can be configured by optional communication modules for required communication interfaces. The command and actual values for pressure and flow can be adjusted and monitored by a superior machine control using either an analog interface or an industry standard bus interface, thus providing an easy and flexible integration into machine control systems.

Functionality

Using an internal gear pump of type PGH, the required flow is directly regulated by the motor speed. The pumps are optimized for variable-speed operation and achieve a high overall efficiency due to low leakage, and operate with minimum noise development.

In operation, sensors measure pressure, actuator position** and the servo motor speed. These values are used by the servo control. The command values which are set by the machine control are compared by the IndraDrive according to the system requirements with the setting of the pump drive speed.

Decisive advantages of the SvP system:

- ▶ High efficiency servo motors with versions for a standardized and direct assembly of pumps
- ▶ High dynamics and closed-loop accuracy
- ▶ Broad range of control functions

SvP block diagram

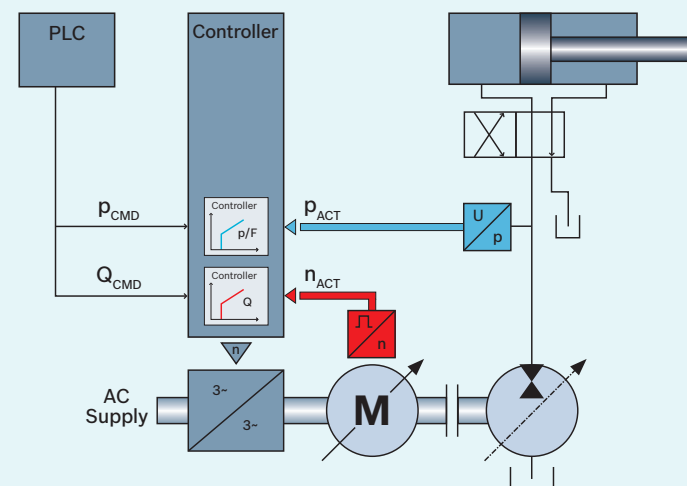

* p/Q: Pressure-/Flow rate control

SvP 5020

Features

- ▶ Nominal power up to 65 kW (87 hp)
- ▶ Maximum system pressure with PGH pump up to 350 bar, with A10 up to 315 bar
- ▶ Suitable for axis control in open and closed hydraulic systems
- ▶ 2-quadrant operation

Components

- ▶ Motor-pump unit MPA01 or MPA02 (direct coupling) or motor-pump assemblies with standard coupling consisting of
 - MSK or MS2N motor, air- or liquid-cooled
 - Internal gear pump type PGH
 - Standard coupling elements
- ▶ Pump control EFC 5610 with optional communication modules
- ▶ Individually configured motor-pump units of servo motors and pumps such as PGH, A10, A4

Application

- ▶ The SvP 5020 offers performance up to 65 kW (87 hp) and is ideal in the following fields of application:
 - Injection molding machines
 - Die casting machines
 - Press lines
- ▶ The controller is optimized for Sytronix applications and compensates for the characteristics of hydraulic systems to provide optimal dynamics and accuracy

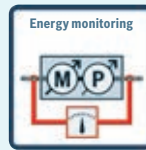

Energy monitoring

Enhanced energy monitoring functions lead to energy-optimized systems

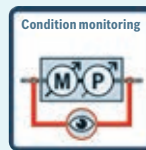

Condition monitoring

Enhanced monitoring functions for increased system availability

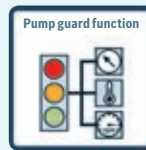

Pump guard function

A unique pump guard function has been integrated in all SvP systems extending the life cycle and preventing machine standstill

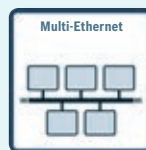

Multi-Ethernet

Support of standard communication protocols provides flexibility for the integration into a multitude of system topologies

SvP 5020 with PGH, MS2N/ MSK forced-ventilated

PRODUCT SELECTION GUIDE FOR SYTRONIX SvP 5020 WITH PGH

Pumps $n_{max} = 3000 \text{ rpm}$						Motors (forced-ventilated)												
Type	Size	p_{cont} [bar]	p_{max} [bar]	Q_{max} [l/min]	V_g [ccm]	MS2N07			MS2N10				MSK133					
						COBN	DOBN	EOBN	COBN	DOBN	EOBN	FOBN	B-0202	C-0202	D-0202	E-0202		
						19.8	35.5	49.5	43.2	82.4	119.0	142.0	152.0	204.0	263.0	293.0		
						38.8	79.7	119.5	76.8	155.0	234.0	287.0	320.0	425.0	520.0	630.7		
						$p_{RMS}^* \text{ [bar]}$												
						$M_{cont} \text{ [Nm]}$ $M_{max} \text{ [Nm]}$												
PGH2	005	315	350	15	5.2	239	315											
	006	315	350	18	6.5	191	315											
	008	315	350	24	8.2	125	272	315										
PGH3	011	315	350	33	11.0	113	203	283	247	315								
	013	315	350	39	13.3	94	168	234	204	315								
	016	315	350	48	16.0	78	139	194	170	315								
PGH4	020	315	350	60	20.1	62	111	155	135	258	315							
	025	315	350	75	25.3	49	88	123	107	205	296	315	315					
	032	315	350	100	32.7	38	68	95	83	158	229	273	292	315				
	040	315	350	120	40.1	31	56	78	68	129	186	222	238	315				
	050	250	310	150	50.7	25	44	61	54	102	147	176	188	250				
PGH5	063	210	250	190	65.5	19	34	47	41	79	114	136	146	196	210			
	063	315	350	190	64.7				42	80	116	138	148	198	255	285		
	080	315	350	240	81.4				33	64	92	110	117	157	203	226		
	100	315	350	300	100.2				27	52	75	89	95	128	165	184		
	125	315	350	375	125.3				22	41	60	71	76	102	132	147		
	160	210	260	480	162.8				17	32	46	55	59	79	102	113		
	200	170	210	600	200.4					26	37	45	48	64	82	92		
250	135	170	750	250.5					21	30	36	38	51	66	73			
						$K \text{ [%]}$												
Pump Drive	EFC5610	-11K0	43.7	24.3		97												
		-15K0	58.3	32.4		129												
		-18K5	70.6	39.2		156	82											
		-22K0	81.0	45.0		179	94											
		-30K0	109.4	60.8			127	97				97						
		-37K0	132.7	73.7			154	117				117	91					
		-45K0	160.2	89.0				141	93			141	110	89				
		-55K0	194.4	108.0				172	113			171	133	108	94			
		-75K0	264.6	147.0					153				181	147	128			
		-90K0	316.8	176.0					183					176	153			

* RMS pressure without consideration of the efficiency

Detailed component information

Motors: see "Motors" starting on page 53

Pumps: Data sheet RE 10227

Pump drive: Catalog R999000019

Detailed explanation of the tables on page 9

Performance curve for SvP 7020 – forced-ventilated motor

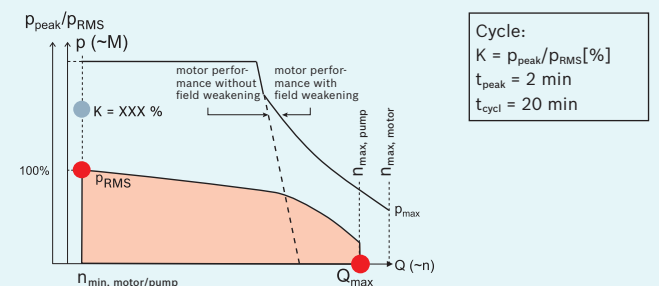

SvP 5020 with A10VZO, MS2N/ MSK forced-ventilated

PRODUCT SELECTION GUIDE FOR SYTRONIX SvP 5020 WITH A10VZO FORCED-VENTILATED

Pumps $n_{max} = 3000 \text{ rpm}$							Motors (forced-ventilated)											
Type	Size	p_{cont} [bar]	p_{max} [bar]	n_{max} [1/min]	Q_{max} [l/min]	V_g [ccm]	MS2N07			MS2N10				MSK133				
							COBN	DOBN	EOBN	COBN	DOBN	EOBN	FOBN	B-0202	C-0202	D-0202	E-0202	
							19.8	35.5	49.5	43.2	82.4	119.0	142.0	152.0	204.0	263.0	293.0	
							38.8	79.7	119.5	76.8	155.0	234.0	287.0	320.0	42.0	520.0	630.7	
							p_{RMS}^* [bar]										M_{cont} [Nm]	M_{max} [Nm]
A10VZO	010	250	250	3600	900	10.5	118	212										
	018	315	280	3300	1039	18.0	69	124	173	151	288							
	028	315	280	3000	945	28.0	44	80	111	97	185	267						
	045	315	280	3000	945	45.0	28	50	69	60	115	166	198	212	285			
	071	280	280	2550	714	71.1	17	31	44	38	73	105	125	134	180	232	259	
	100	280	280	2300	644	100.0		22	31	27	52	75	89	96	128	165	184	
	140	280	280	2200	616	140.0		16	22	19	37	53	64	68	92	118	131	
180	280	280	1800	504	180.0				17	15	29	42	50	53	71	92	102	
							K [%]											
Pump Drive	EFC5610	-11K0-3P4		43.7	24.3													
		-15K0-3P4		58.3	32.4													
		-18K0-3P4		70.6	39.2													
		-22K0-3P4		81.0	45.0													
		-30K0-3P4		109.4	60.8													
		-37K0-3P4		132.7	73.7													
		-45K0-3P4		160.2	89.0													
		-55K0-3P4		194.4	108.0													
		-75K0-3P4		264.6	147.0													
		-90K0-3P4		316.8	176.0													

* RMS pressure without consideration of the efficiency

Detailed component information

Motors: see "Motors" starting on page 53
 Pumps: Data sheet RE 10227
 Pump drive: Catalog R999000019

Detailed explanation of the tables on page 9

Performance curve for SvP 7020 – forced-ventilated motor

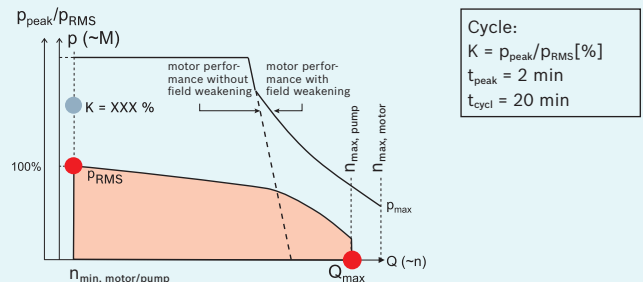

SvP 5020 with PGH, MS2N/ MSK liquid-cooled

PRODUCT SELECTION GUIDE FOR SYTRONIX SvP 5020 WITH PGH LIQUID-COOLED

Pumps $n_{max} = 3000 \text{ rpm}$						Motos (liquid-cooled)												
Type	Size	p_{cont} [bar]	p_{max} [bar]	Q_{max} [l/min]	V_g [ccm]	MS2N07		MS2N10				MSK133						
						COBN	DOBN	E0BN	COBN	DOBN	E0BN	FOEN	FOCN	B-0203	C-0203	D-0203	E-0203	
						26.6	55.0	83.0	51.7	107.5	162.0	136.0	181.0	162.0	232.5	290.0	342.0	
						38.8	79.7	119.5	76.8	155.0	234.0	287.0	287.0	300.0	400.0	500.0	583.0	
						p_{RMS}^* [bar]												
						M_{cont} [Nm] M_{max} [Nm]												
PGH2	005	315	350	15	5.2	315												
	006	315	350	18	6.5	257	315											
	008	315	350	24	8.2	204	315											
PGH3	011	315	350	33	11.0	152	314	315	295	315								
	013	315	350	39	13.3	126	260	315	244	315								
	016	315	350	48	16.0	104	216	315	203	315								
PGH4	020	315	350	60	20.1	83	172	259	162	315								
	025	315	350	75	25.3	66	137	206	128	267	315							
	032	315	350	100	32.7	51	106	159	99	207	311	261	315	311	315			
	040	315	350	120	40.1	42	86	130	81	168	254	213	284	254	315			
	050	250	250	150	50.7	33	68	103	64	133	201	169	224	201	250			
PGH5	063	210	250	190	65.5	26	53	80	50	103	155	130	174	155	210			
	063	315	350	190	64.7			50	104	157	132	176	157	226	282	315		
	080	315	350	240	81.4			40	83	125	105	140	125	179	224	264		
	100	315	350	300	100.2			32	67	102	85	113	102	146	182	214		
	125	315	350	375	125.3			26	54	81	68	91	81	117	145	171		
	160	210	260	480	162.8			20	41	63	52	70	63	90	112	132		
200	170	210	600	200.4			16	34	51	43	57	51	73	91	107			
250	135	170	750	250.5					27	41	34	45	41	58	73	86		
						K [%]												
Pump Drive	EFC5610	-15K0	350.0	200.0	105													
		-18K0	20.0	12.1	127													
		-22K0	36.0	21.3	146													
		-30K0	54.0	35.0			94								88			
		-37K0	70.7	42.4			114	82						106				
		-45K0	110.0	68.5			138	99	97					128	96			
		-55K0	150.0	99.7			167	120	117	85	156	116	88	80				
		-75K0	210.0	150.7					163	160	116			158	120	109		
		-90K0	300.0	150.1							139			144	130			

* RMS pressure without consideration of the efficiency

Detailed component information

Motors: see "Motors" starting on page 53

Pumps: Data sheet RE 10227

Pump drive: Catalog R999000019

Detailed explanation of the tables on page 9

Performance curve for SvP 7020 – liquid-cooled motor

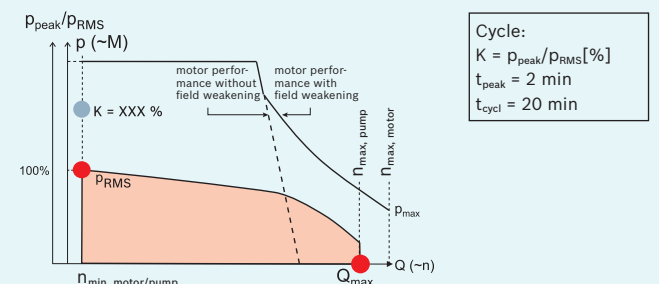

Sytronix – individual solutions

Apart from the pre-configured systems of the series FcP, DRn, SY(H)DFEn as well as SvP, the Sytronix product range also offers individual solutions. These systems can be planned and configured by combining modules and individual components, using questionnaires on application criteria and system parameters, in collaboration with Rexroth specialists.



Rexroth – synonymous with planning security

- ▶ Sytronix product range for customized solutions
- ▶ Products with excellent dynamics and closed-loop accuracy
- ▶ Proven product quality for high machine reliability
- ▶ Industry-specific consulting and technical support
- ▶ Global presence and support

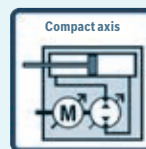

Compact axis

With Sytronix, you can implement compact and tankless axis solutions

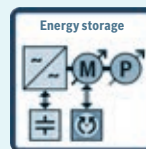

Energy storage

Energy storage via a capacity on the DC bus or a flywheel mass leads to downsizing of the drive system and to a reduction of power peaks

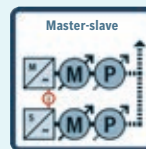

Master-slave

With master-slave, intelligently connected drive systems can cover higher power ranges

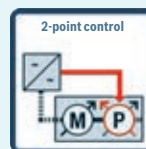

2-point control

The use of axial piston pumps with 2-point adjustment enables downsizing of the drive system



Hydraulic Gear

The use of axial piston pumps with stepless adjustment enables downsizing of the drive system

Components and modules for Sytronix systems can be found starting on page 44

8 steps for a system solution

Step	Example	Help
1 Definition of system requirements <ul style="list-style-type: none"> ▶ Hydraulic circuit diagrams (open/closed circuit) ▶ General conditions (liquid, filtration, supply voltage, interface, basic or advanced control parts, etc.) ▶ Load cycles (pressure, flow, worst case, etc.) ▶ Performance (closed-loop accuracy, dynamics) 	Pressure supply for core-shooting machines <ul style="list-style-type: none"> ▶ Open hydraulic circuit ▶ Constant pressure: 100 bar ▶ Average flow: 30 l/min ▶ Maximum flow: 100 l/min ▶ Liquid: HLP 46 ▶ Mains voltage: 400 VAC ▶ Analog command values ▶ High dynamics 	Guidelines for energy-efficient hydraulic power units Questionnaire RE 62246
2 Selection of required Sytronix functions <ul style="list-style-type: none"> ▶ Control quality ▶ Dynamics ▶ Open or closed control loop ▶ Pressure or flow control ▶ Alternating pressure/flow control ▶ Force control, speed control, position control 	Servo motor comparable system such as SVP 7020 <ul style="list-style-type: none"> ▶ Pressure control ▶ High dynamics 	System selection As orientation, refer to the system overview on pages 6 and 7
3 Pump selection <ul style="list-style-type: none"> ▶ Maximum pressure ▶ Maximum flow ▶ Minimum speed ▶ Open or closed control loop 	PGH4-3X/050 internal gear pump <ul style="list-style-type: none"> ▶ Continuous nominal pressure: 315 bar ▶ Maximum flow: 150 l/min ▶ Open control loop 	SytronixSize program for system dimensioning Pumps Starting on page 63
4 Definition of drive requirements (Load cycle conversion using the pump displacement) <ul style="list-style-type: none"> ▶ RMS torque, maximum torque ▶ Average speed, maximum speed 	Parameter <ul style="list-style-type: none"> ▶ RMS torque: 85 Nm ▶ Maximum torque: 118 Nm ▶ Average speed: 630 rpm ▶ Maximum speed: 2,050 rpm 	SytronixSize program for system dimensioning
5 Combination drive and motor <ul style="list-style-type: none"> ▶ Torques, speed ▶ Drive type ▶ Compact or modular drive system ▶ Electrical connection at the motor ▶ Motor cooling type ▶ Encoder 	IndraDrive C with MPA01 HCS03.1E-W0100-A-05-NNBV MPA01-PGH4P-NN-VBB-M11EBHA-S3F-NN <ul style="list-style-type: none"> ▶ Torque with fan: 105 Nm ▶ Maximum torque: 180.6 Nm ▶ Maximum speed: 2,400 rpm 	SytronixSize program for system dimensioning Power units, motor-pump units, motors Starting on page 47
6 Definition of the controller configuration (IndraDrive only) <ul style="list-style-type: none"> ▶ Interface to the higher-level control system ▶ Encoder ▶ Inputs and outputs ▶ Safety technology 	Basic-Steuerteil , extended scope with STO option CSB02.1B-ET-EC-NN-L3-NN-NN-FW <ul style="list-style-type: none"> ▶ High performance ▶ Multi-Ethernet interface ▶ Standard encoder ▶ Standard operating panel ▶ STO option card (Safe Torque Off) 	Control units Page 50
7 Definition of the firmware functionality (for IndraDrive only) <ul style="list-style-type: none"> ▶ Basic OPEN or CLOSED CONTROL LOOP package ▶ Extension packages ▶ Motion logic ▶ Technology functions 	Closed control loop Basic package and SvP application software FWA-INDRV*-MPB-20VRS-D5-1-SYX-TF FWS-MLDSYX-IMC-02VRS-D0-MP20 <ul style="list-style-type: none"> ▶ Technology functions with extension package ▶ Application software for pressure and flow control (IMC) 	Firmware Page 57
8 Selection of accessories <ul style="list-style-type: none"> ▶ Mains filters and throttles ▶ Braking resistance, brake units ▶ Additional capacity ▶ Electrical connections ▶ Engineering software ▶ Pressure transducer ▶ Mechanical connections 	<ul style="list-style-type: none"> ▶ Mains filter NFD03.1-480-130 ▶ Mains throttle HNL01.1E-0362-N0080-A-500-NNNN ▶ Power cable RKL0042/005.0 ▶ Encoder cable RKG0047/005.0 ▶ Basic accessories HAS01.1-255-NNN-CN ▶ Shield connection HAS02.1-005-NNN-NN ▶ Pressure transducer R901342027 HM 20-2X/250-H-K35 	Accessories Starting on page 71 Motor-Pumpen-Einheiten Startin on page 47 IndraWorks engineering tool

Individual components for your pump drive system

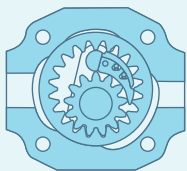
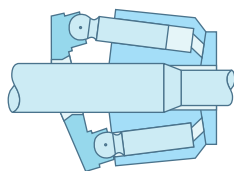
Pump	Internal gear pump		Axial piston pump		
					
	Thanks to the particularly low noise level of the internal gear pump, additional noise insulation at the power unit is usually not necessary.		In many cases, reduction of the torque in partial load operation allows for smaller motor ratings. The drain port of the pump provides for sufficient lubrication and cooling without external measures.		
Type	PGF	PGH	A10	A15	A4
n_{\min} with p_{cont} [rpm]	200	200	50	50	50
n_{\max} [rpm]	3600	3000	3600 ... 1800	2400 ... 1800	2600 ... 1500
V_{geo} [cm ³]	1,7 ... 40	20 ... 250	6 ... 180	110 ... 280	40 ... 750
p_{cont} [bar]	210	315	315	350	350
p_{\max} [bar]	≤ 250	≤ 350	≤ 350	≤ 420	≤ 400
P_{hydmax} [kW (hp)]	34	134	151	294	656
Operating mode	2, 1 – Q	2, 1 – Q	4, 2, 1 – Q	2, 1 Q	4, 2, 1 – Q
Characteristic	geräuscharm	geräuscharm	universal	universal	universal
Documentation	RD10213	RD10227	RD91485	RD92800	RD92050

Frequency converter	EFC 5610	IndraDrive
Interface	analog/digital Sercos & Multi-Ethernet, Profibus	analog/digital, connectivity with Sercos & Multi-Ethernet, Profibus and CAN
Functionality	alternating p/Q control	alternating p/Q control, optional position and force control, integrated PLC
Pump guard	Basic	Advanced
Commissioning	Display, IndraWorks	IndraWorks

Motor	MOT-FC	MSK/MS2N
Dynamics (acceleration ¹)	>300 ms	<100 ms
Position control ²	–	++
Minimum speed ³ (leakage)	100	0
Dimensions	O	+
Price	++	O

¹) Acceleration to 1500 rpm

²) Only possible with IndraDrive

³) Normally the pump is the limiting component in the system

Sytronix retrofit: Efficiency booster for installed systems

The high degree of modularity of hydraulics on the component level has many advantages. One of the most important advantages: It simplifies the economical retrofitting of constant units with the help of the Sytronix variable-speed pump drives.

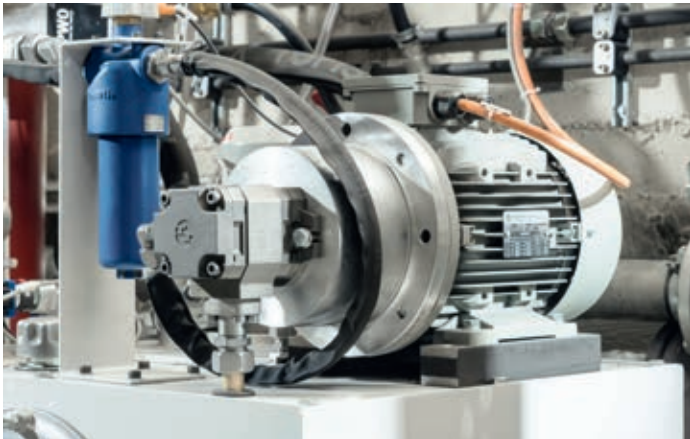

Instantly and sustainably lower the energy consumption of your production without investing in new machines. With very little effort, we can turn a constant unit into an energy-efficient system, producing flow in line with demand. Existing hydraulic systems often do not need to be modified – which further reduces the effort for retrofitting.

Experienced experts in more than 80 countries will support you during the entire retrofitting process. Specially developed tools determine the potential savings for your application well in advance. Following project planning on the basis of our extensive application experience, our service technicians will carry out the fast on-site assembly and commissioning at your location. Open interfaces with all common fieldbuses and Ethernet protocols facilitate integration into your system.

Beyond custom project planning of retrofitting, Rexroth has developed a standardized retrofitting kit for the refitting of machine tools together with a global leader in machine tool manufacturing. This further reduces the effort required for refitting and ensures quick gains in production efficiency.

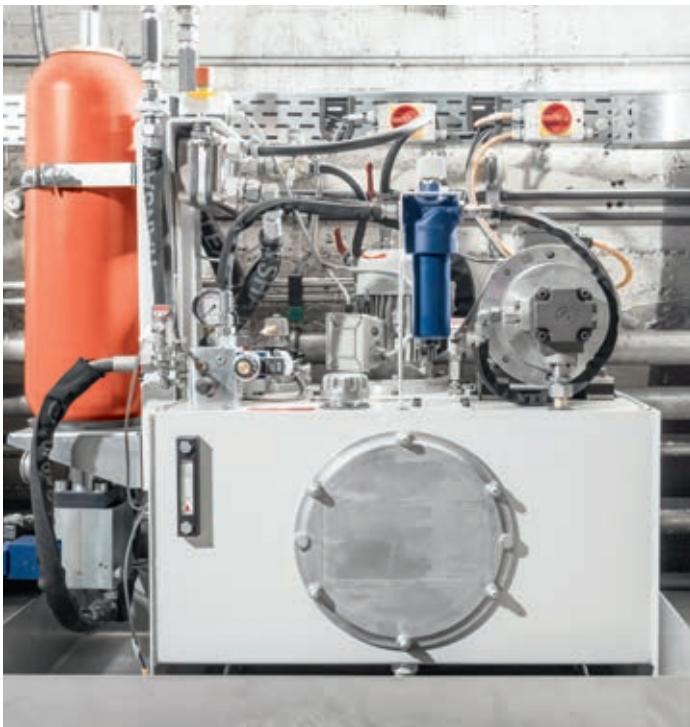

SytronixSize

With the high-performance tool SytronixSize, Rexroth fundamentally simplifies the perfect design of electrohydraulic drive systems. The intuitive handling allows the user to dimension a system in a guided form, in few steps and in a short time. SytronixSize combines the model-based calculation of the variables from the hydraulic and electric individual components and is able to display a low-noise and energy-efficient solution on the basis of the application-specific use.

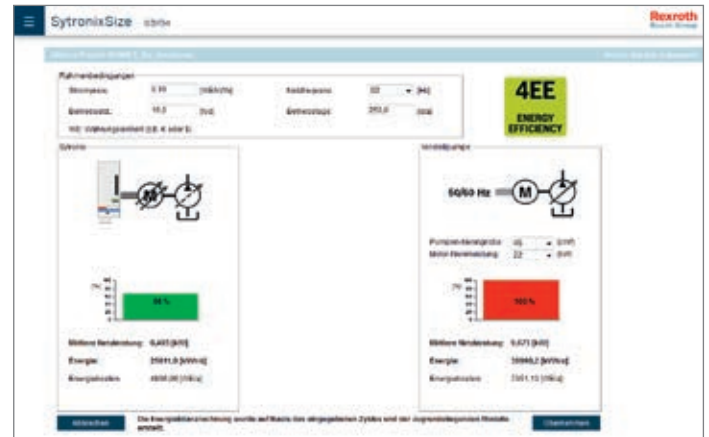

By means of SytronixSize, hydraulic and electrical components can be dimensioned on the basis of application-specific specifications. As all product-relevant data and models are contained, the design process is automated.

In the energy calculation, the system is then compared to two conventional systems and the user is directly shown the energy savings. Next, the noise emission over the load cycle is analyzed. The tool is completed by documentation with any and all relevant information about the application and the proposed components.

Technical key data

- ▶ Selection from the complete Sytronix product range
- ▶ No installation required
- ▶ Several languages available
- ▶ Can be used offline
- ▶ Automatic update

Advantages thanks to special product features

- ▶ Application cycle is considered
- ▶ Thermal utilization of the components is checked
- ▶ Is always state-of-the-art
- ▶ Precise and reliable representation of the results
- ▶ Design of pump, motor and drive controller
- ▶ Predefined sample applications

More information is available on the Internet at www.boschrexroth.com/sytronixsize

Komponenten und Module



For the configuration of customer-specific variable-speed pump drives, Rexroth offers extensive pump, power unit, motor and control software series. Apart from that, we support you in the selection and combination of individual components for your individual Sytronix system.

45 MOTOR-PUMP UNITS

Motor and pumps are available as pre-configured units

48 DRIVES

Drives for synchronous or standard motors

57 MOTORS

Synchronous and asynchronous motors for pump drives in Sytronix systems

61 PUMPS

Internal gear or axial piston pumps for a wide range of system pressures

69 ACCESSORIES

Extensive selection of Rexroth accessories including mains filters, braking resistors, mains throttles, power and encoder cables, auxiliary components (connection kits, attachment kits and assembly kits) and control cabinets

Modular construction kit with tool support of MOT-FC and PGF, PGH, A10, A4, SY(H)DFEn

Features

- ▶ Wide range of pre-configured motor-pump units
- ▶ Available with different pump configurations, depending on the pump type
- ▶ Mounting options: variable, based on motor size
- ▶ Horizontal and vertical mounting possible

Product description

The motor-pump assemblies with asynchronous motor are usually delivered unmounted. Our Sales team will support you in the creation of the complete parts list.

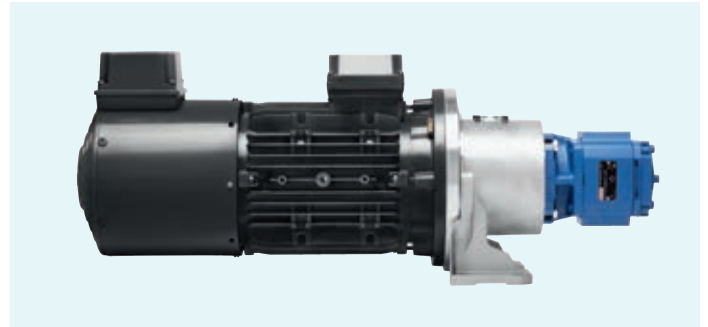

Mounting types dependent on the cooling mode

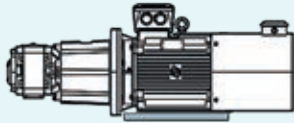
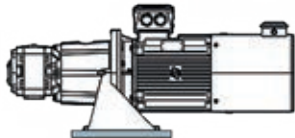
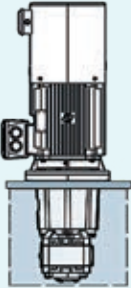
Motor-pump unit	Mounting type A	Mounting type B	Mounting type V
			
MOT-FC IC 411 / TEFC (self-ventilated)	0.25 ... 315 kW (0.3 ... 420 hp)	1.1 ... 15 kW (1,5 ... 20 hp) not for PGF1	0.25 ... 315 kW (0.3 ... 420 hp)
MOT-FC IIC 416 / TEBC (forced-ventilated)	11 ... 315 kW (15 ... 420 hp)	1.5 ... 15 kW (2 ... 20 hp) not for PGF1	1.5 ... 315 kW (2 ... 420 hp)

Motor-pump unit direct coupling MPA01 and MPA02

Features

- ▶ Direct coupling: Pump shaft is inserted into the internally geared motor shaft in a particularly space-saving manner
- ▶ Available for motor type MS2N10 and internal gear pump PGH4
- ▶ Available for motor types MSK133 and internal gear pump PGH5
- ▶ Horizontal and vertical mounting possible
- ▶ Mounting options: flange, foot mount, or motor feet (only MSK133)
- ▶ MS2N with compact one-piece pump foot

Product description

MPA01 (MSK in combination with PGH) and MPA02 (MS2N in combination with PGH) offer a compact solution with numerous motor and pump options.

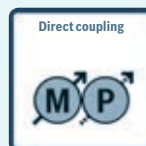

Direct coupling

Direct coupling enables a compact design, achieving better dynamics and reduced costs

Mounting types

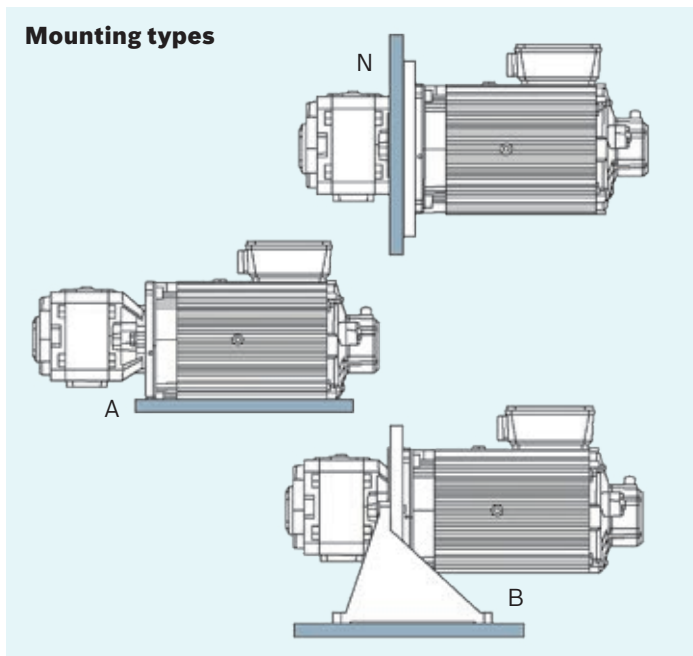

Detailed information:

Operating instructions: R911339824

Assembly instructions: R911339499, R911341600

Technical data

Motor	MS2N10	MSK133
Overall length	C, D, E, F	B, C, D, E
Cooling	Convection, forced-ventilated, liquid-cooled	forced-ventilated, liquid-cooled
Pump	PGH4	PGH5
Size	20 ... 63	63 ... 160
Assembly option	F, N	A, B, N

Pre-configured motor-pump combinations of Servo motor and PGH, A10, A4

Features

The standard coupling allows for many different motor-pump units which are not possible with the direct coupling – e.g. combination with axial piston pump, the servo motor MS2N07 or combination with internal gear pump.

Product description

Motor-pump assemblies with standard coupling use a conventional coupling between motor and pump with a pump carrier suitable for servo-drives.

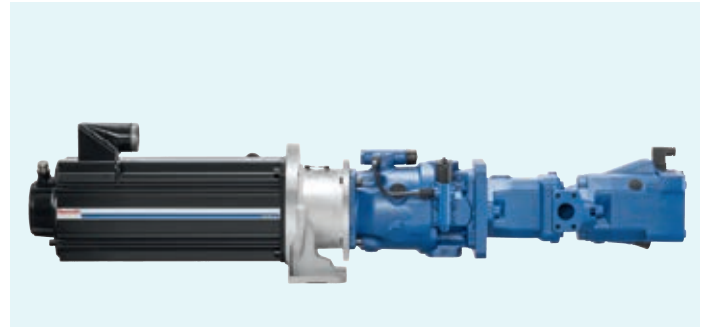

Mounting types

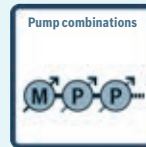
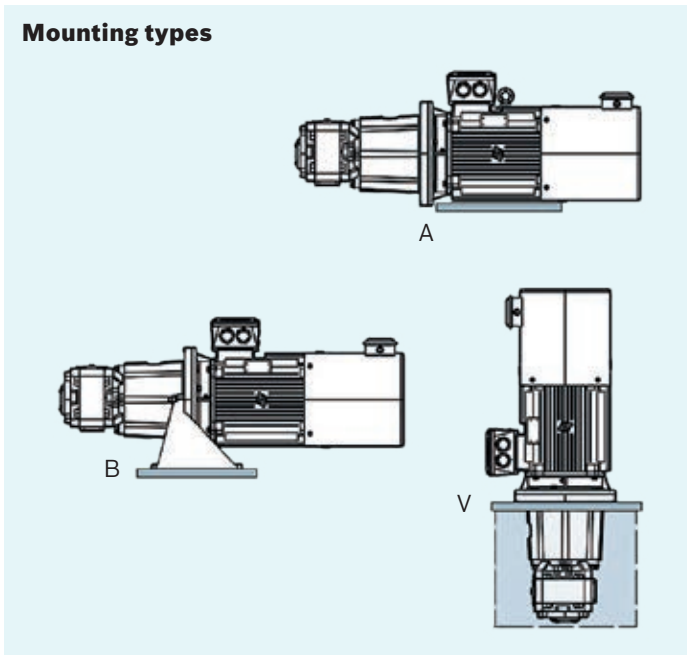

Pump combinations

The use of double pump systems enables downsizing of the drive system while cooling and filtration functions in the hydraulic circuit can be transferred

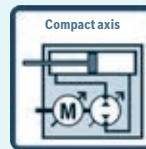

Compact axis

With Sytronix, you can implement compact and tankless axis solutions

Technical data

Motor	MS2N07	MS2N10	MSK133
Overall length	C, D, E	C, D, E, F	B, C, D, E
Cooling	Convection, forced-ventilated, liquid-cooled	Convection, forced-ventilated, liquid-cooled	forced-ventilated, liquid-cooled
Pump	PGH2, PGH3, PGH4, A10	PGH4, PGH5, A10	PGH5, A10
Size	5 ... 8, 11 ... 16, 20 ... 63, 10 ... 28	25 ... 63, 63 ... 250, 18 ... 71	63 ... 250, 71 ... 180
Assembly option	B, V	B, V	A, B, V

Drives

Drives

Drive units are converters or inverters based on the IndraDrive product family or frequency converters of type EFC. The IndraDrive unit consists of a power component and a control section for servo motors and conventional motors.

The part of the drive control equipped with all the control functions and interfaces for installation in the power unit is referred to as the control section. The power component contains the power electronics to control the motors and is used to hold the control section.

The converter (IndraDrive C - HCS) takes the mains voltage with its fixed amplitude and frequency and generates a three-phase alternating current with variable amplitude and frequency.

The inverter (IndraDrive M - HMS) takes the DC bus voltage and generates a three-phase alternating current with variable amplitude and frequency.



The frequency converter ERC 5610 combines the supply and control functions for standard asynchronous motors in one device. The frequency converter converts the fixed amplitude and frequency mains voltage into variable amplitude

IndraDrive – compact drives HCS

- ▶ Power range from 1.5 kW to 110 kW (2 to 150 hp), with maximum current from 12 A to 350 A
- ▶ High overload capacity
- ▶ Compact set-up for single-axis applications
- ▶ Can be connected to a converter for cost-effective solutions
- ▶ Direct mains connection from 200 V to 500 VAC

IndraDrive – modular drives IndraDrive ML

- ▶ Power range up to 4 MW
- ▶ High overload capacity
- ▶ Modular design for machines with several regulated axes
- ▶ Feedback-enabled
- ▶ Flexible for concepts such as kinetic buffering (energy storage with the flywheel mass)
- ▶ Direct mains connection from 200 V to 500 VAC

Frequency converter EFC5610

The frequency converter is the perfect drive solution for automation applications with a power range up to 160 kW (200 hp).

Firmware

Unit-specific software for automation applications. With the IndraDrive servo-drives and the EFC frequency converters, the firmware is stored in the read-only memory. IndraDrive has the option of updating the firmware using Compact-Flash.

Drives – IndraDrive Cs Converters HCS01.1E

Features

- ▶ 2 series for direct mains connection to 110 – 230 VAC and/or 200 – 500 VAC
- ▶ Suitable for motors up to 9 kW (12 hp) continuous power operation
- ▶ Allows for device replacement without PC
- ▶ IEC-conform motion logic IndraMotion MLD (option)
- ▶ Integrated safety technology Safe Torque Off or Safe Motion up to category 4 PLe according to ISO 13849-1 and/or SIL 3 according to IEC 62061 (option)
- ▶ Integrated braking resistance; alternatively, you can also connect an external braking resistance

Product description

Apart from the space-saving design and excellent performance data, IndraDrive Cs distinguishes itself by an extensive range of Ethernet-based communication interfaces.



Detailed information:

Instructions: R911322210

Catalog: R999000019

Technical data

HCS01.1E		1 phase	3 phases
Continuous current ¹⁾	A	1.4 ... 7.6	2.0 ... 21.0
Maximum current	A	3.3 ... 18.0	5.0 ... 54.0
DC bus continuous power without/with throttle	kW (hp)	0.15 ... 1.8 / - (0.2 ... 2.4 / -)	0.46 ... 9 / 4 ... 14 (0.6 ... 12.1 / 5.4 ... 18.8)
Mains voltage	V	1 AC 200 ... 230 (±10 %)	3 AC 200 ... 500 (±10 %)
Dimensions (W x H x D)	mm	50 x 215 x 196 bis 70 x 268 x 196	50 x 215 x 196 bis 130 x 268 x 196
Weight	kg	0.72 ... 1.7	0.72 ... 4.22

All data refer to nominal values at a mains voltage of 3 AC 400 V and a switching frequency of 4 kHz

¹⁾ With an output frequency below 4 Hz, the output current is reduced

Drives – IndraDrive Converters HCS02.1E

Features

- ▶ Continuous power from 1.5 kW to 11 kW (2 to 15 hp)
- ▶ Internal or external braking resistance
- ▶ 2.5 x overload capacity
- ▶ Maximum current from 28 A to 70 A
- ▶ Can be connected to a converter for cost-effective solutions
- ▶ Direct mains connection from 200 V to 500 V AC

Product description

IndraDrive HCS02 series of drives integrates inverter and power supply in one unit. Contains line connections for the compact construction of single axis applications.



Detailed information:

Instructions R911309636

Catalog R999000019

Technical data

Type		HCS02.1E
Continuous current ¹⁾	A	11.3 ... 28.3
Maximum current	A	28.3 ... 70.8
DC bus continuous power without/with throttle	kW (hp)	5.1 ... 9 / 5.1 ... 14 (6.8 ... 12.1 / 6.8 ... 18.8)
Maximum power without/with throttle	kW (hp)	8 ... 14 / 10 ... 19 (10.7 ... 18.8 / 13.4 ... 25.5)
Mains voltage	V	3 AC 200 ... 500.1 AC 200 ... 250 (±10 %)
Continuous input current	A	13 ... 30
Dependence of power on the mains voltage		at $U_{LN} < 400$ V: power reduction by 1 % per 4 V bei $U_{LN} > 400$ V: Lpower gain by 1 % per 5 V
Maximum braking power	kW (hp)	10 ... 25 (13.4 ... 33.5)
External control voltage	V	DC 24 ±20 % (DC 24 ±5 % when supplying a motor holding brake)
Power consumption	W	14 ... 23
Dimensions (W x H x D)	mm	65 to 105 x 352 x 252
Weight	kg	3.8 ... 6.8

All data refer to nominal values at a mains voltage of 3 AC 400 V and a switching frequency of 4 kHz

¹⁾ With an output frequency below 4 Hz, the output current is reduced

Drives – IndraDrive Converters HCS03.1E

Features

- ▶ Continuous power with/without throttle: 13 to 60 / 25 to 120 kW (17 to 80 / 34 to 161 hp)
- ▶ High overload capacity
- ▶ Maximum current from 70 to 350 A
- ▶ Can be connected to a converter for cost-effective solutions
- ▶ Direct mains connection from 400 V to 500 VAC
- ▶ Internal brake chopper optional for controlling a braking resistance

Product description

IndraDrive HCS03 series of drives integrates inverter and power supply in one unit and comprises line connections for the compact construction of single axis applications.



Detailed information:

Instructions R911309636

Catalog R999000019

Technical data

Type		HCS03.1E
Continuous current ¹⁾	A	45 ... 200
Maximum current	A	70 ... 350
DC bus continuous power without/with throttle	kW (hp)	13 ... 60 / 25 ... 120 (17.4 ... 80 / 33.5 ... 160.9)
Maximum power without/with throttle	kW (hp)	20 ... 115 / 40 ... 210 (26.8 ... 154 / 53 ... 281.5)
Mains voltage (+10 %/–15 %)	V	3 AC 400 ... 500
Dependence of power on the mains voltage		at $U_{LN} < 400$ V: Power reduction by 1 % per voltage reduction by 4 V
Maximum braking power	kW (hp)	42 ... 137 (56 ... 183)
External control voltage	V	DC 24 ±20 % (DC 24 ±5 % when supplying a motor holding brake)
Power consumption	W	22.5 ... 30
Dimensions (H x W x D)	mm	125 ... 350 x 440 x 315
Weight	kg	13 ... 38

All data refer to nominal values at a mains voltage of 3 AC 400 V and a switching frequency of 4 kHz

¹⁾ With an output frequency below 4 Hz, the output current is reduced

Drives – IndraDrive

Power supply HMV01.1E, HMV01.1R

Features

- ▶ Power range from 18 kW to 120 kW (25 to 160 hp)
- ▶ Direct mains connection from 400 V to 480 VAC
- ▶ Protection class IP20
- ▶ Energy-saving power recovery (optional)
- ▶ Integrated mains contactor
- ▶ Integrated braking resistance

Product description

IndraDrive type HMV power supply units are used in combination with modular HMS inverters.

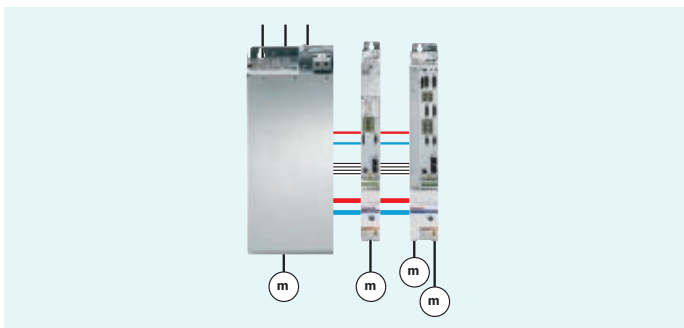

Detailed information:

Catalog R999000019

Technical data

Type	HMV01.1E/HMV01.1R	
Mains voltage	V	3 AC 400 ... 480 (+10 %/–15 %)
Mains frequency	Hz	48 ... 62
DC bus continuous power	kW (hp)	18 ... 120 (24.1 ... 160)
Overload capacity		1,5x / 1,5 ... 2,5x
Suitable control cabinet depth	mm	HMx01: 400
Mains contactor/brake chopper/braking resistance		internal ¹⁾ / internal ¹⁾ / internal ¹⁾
Control voltage DC 24 V		external
Protection class		IP20
Installation height	m	1000 above sea level, with derating to 4000 ²⁾
Ambient temperature	°C	0 to +40, with derating to +55
Cooling type		Air cooling
CE mark		Low-Voltage Directive 73/23/EEC, EMC Directive 89/336/EEC
Certifications/EMC		EN 61800-5-1, EN 61800-3, UL 508C, C22.2 No. 14-05/C3 (EN 61800-3)

All data refer to nominal values at a mains voltage of 3 AC 400 V and a switching frequency of 4 kHz

¹⁾ Not applicable to HMV01.1R-W0120; ²⁾ to 3000 m

Drives – IndraDrive Inverters HMS01

Features

- ▶ Modular single-axis inverters
- ▶ Single-axis inverters with a maximum current from 20 A to 350 A
- ▶ If required, you can also use the IndraDrive ML drive control units
- ▶ Space-saving design with multi-axis applications
- ▶ Can be optionally powered via power supply unit
- ▶ Power sharing via conventional DC bus
- ▶ Can be connected to a converter for cost-effective solutions

Product description

IndraDrive HMS inverter series for single and dual axis application in modular drive systems. The devices have a power output to the drive of a motor and the operation with HMV01/02 power supply units and HCS02 and HC03 drive controllers.



Detailed information:

Instructions R911309636

Catalog R999000019

Technical data

Type		HMS01
Continuous current	A	12,1 ... 250
Maximum current	A	20 ... 350
DC bus power	mF	-/0,14/0,27
External control voltage	V	DC 24 ±20 % (DC 24 ±5 % when supplying a motor holding brake)
Power consumption without control unit and motor brake	W	10 ... 218 (including HAB fan)
Continuous current without control unit and motor brake	A	0,4 ... 9,1 (including HAB fan unit)
Width	mm	50 ... 350
Height	mm	352/440 ¹⁾
Depth	mm	252/309
Weight	kg	5,3 ... 31,7

All data refer to nominal values at a mains voltage of 3 AC 400 V and a switching frequency of 4 kHz

¹⁾ Overall height of HSM01.1N-W0350 with HAB auxiliary fan: 748 mm

Drives – IndraDrive

Control unit CSB02 BASIC/CSH02 ADVANCED

Features

- ▶ Cost-effective solution for standard and high-end applications
- ▶ Integrated motion logic with advanced functions
- ▶ Open interfaces for international use
- ▶ Certified safety technology according to EN 13849-1 and EN 62061 upon request
- ▶ “Safety on board” option
- ▶ Available with standard performance and functionality, version CSB02 BASIC for use with Sytronix

Product description

The ADVANCED control unit offers the highest performance and dynamics. In addition to performance, a wide range of control communications and encoder interfaces are available. Digital and analog inputs and outputs are available at the BASIC control unit using an I/O extension. The control unit can optionally be equipped with certified safety technology according to EN 13849-1 and EN 62061. The ADVANCED control unit is an ideal platform for a drive-integrated PLC with IndraMotion MLD. Using the IndraWorks engineering tool, the complete configuration and commissioning may be completed.

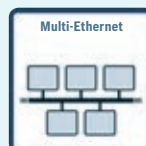

Multi-Ethernet

Support of standard communication protocols provides flexibility for the integration into a multitude of system topologies

The following Ethernet-based bus systems are currently supported: Sercos, EtherCat, EtherNet/IP, ProfiNet

Detailed information:

Instructions R911338962
Catalog R999000019

Technical Data

Type	CSB02.xA	CSB02.xB	CSH02.xB
Controller communication	Connectivity with Sercos & Multi-Ethernet, Profibus and CAN		
Digital inputs	7	11	11
Digital inputs for measuring probes	2	2	2
Digital inputs/outputs (configurable)	1	5	5
Analog inputs	1	3	3
Analog outputs	0	2	2
Relay outputs	2	2	1

Firmware FWS/FWA/ASF

Features

- ▶ Industry-specific functions
- ▶ Integrated logic according to IEC
- ▶ Hydraulic power unit (DRn): constant pressure control with variable displacement pumps with DR or DRG controller
- ▶ Pressure and flow control (IMC) e.g. for injection molding machines
- ▶ Position and force control (PFC)

Product description

The firmware can perform standard drive functions – from simple V/f control to position control. Extension packages provide options for electronic synchronization, servo functions and main spindle drives. The freely-programmable motion logic with integrated PLC according to IEC 61131-3 and ready-to-use functions enable simple execution of complex machine processes.

EFC 5610 for Sytronix have a separate material number. The EFC 5610 pump drive consists of standard EFC 5610 hardware with application specific firmware (ASF) in the case with Sytronix functionality.

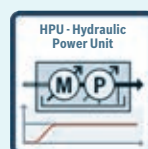
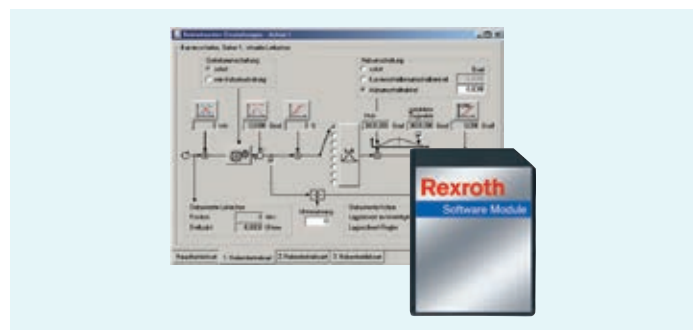

HPU – Hydraulic Power Unit

Application-optimized software for highly dynamic pressure control of hydraulic power units



IMC – Injection Molding Control

Application-optimized software for highly dynamic substitutional pressure and flow control



PFC – Position Force Control

Application-optimized software for highly dynamic position and force control

Detailed information:

Catalog R999000019

Technical Data

Technology functions	FcP	DRn	IMC	PFC
Sytronix series 5020 based on EFC 5610	Pressure control	Pressure control	p/Q control	
Sytronix series 7020 based on IndraDrive			p/Q control	x/F control

Frequency converter EFC 5610

Features

- ▶ Quality and reliability
- ▶ CE conformity
- ▶ UL-listed
- ▶ Simple operation and maintenance
- ▶ LED operating panel
- ▶ Connectivity with Sercos & Multi-Ethernet, Profibus
- ▶ Safety technology STO (Safe Torque Off)

Product description

The EFC 5610 frequency converter is a perfect drive solution for automation of a variety of applications with power ratings up to 160 kW (200 hp). The system offers the operating modes voltage/frequency (V/f) and sensorless vector control (SVC) to suit a wide range of applications.

EFC 5610 for Sytronix have a separate material number. The EFC 5610 pump drive consists of standard EFC 5610 hardware with application specific firmware (ASF) in the case with Sytronix functionality.



Bus modules and IO extensions



Detailed information:

Instructions R912005854

Technical data

Type	EFC 5610	
Nominal motor power	kW (hp)	1 phase (230VAC): 0.4 ... 2.2 (0.5 ... 3.0) 3 phases (200VAC): 0.4 ... 11 (0.5 ... 14.8) 3 phases (400VAC): 0.4 ... 160 (0.5 ... 215.6)
Nominal motor voltage	V	Mains voltage
Mains voltage	V AC	1/3 phases: 200 ... 240 3 phases: 380 ... 480
Mains frequency	Hz	50 ... 60
Overload capacity	%	200 (in 1 s)/150 (in 1 min)
Motor cable length (internal mains filter)	m	depending on size 15 ... 50
Motor cable length (external mains filter)	m	depending on size 30 ... 100
Ambient temperature	°C	-10 ... +45 with derating -10 ... +55

Motors



Standard asynchronous motors MOT-FC

As compared to standard asynchronous motors, MOT-FC have a special, reinforced insulation at the motor windings. This insulation makes sure that voltage peaks due to fast switching processes in the frequency converter do not cause any damage in the motor windings. Accordingly, the MOT-FC is perfectly suitable for the operation with frequency converters.

- ▶ Energy efficiency IE2 (Europe/Asia)
- ▶ NEMA Premium efficiency (North America)
- ▶ Low “total cost of ownership”
- ▶ Standard product series



Synchronous servo motors MSK

Like standard asynchronous motors, MSK and MS2N are driven by three-phase current. Due to the use of permanent solenoids on the rotor, their energy efficiency, dynamics and power density are, however, considerably better. Rotor position and speed are recorded by means of an encoder which is part of the standard equipment of the motors.

- ▶ Maximum torque of up to 631 Nm
- ▶ Protection class: IP65
- ▶ Choice of cooling systems
- ▶ High dynamic performance
- ▶ Compact design



Servo motors MS2N

The MS2N motor series which has been completely newly developed comprises more than 50 motor types. Due to the optimized electro-magnetic design, they achieve a high power density. Individual measured values as well as saturation and temperature data, which are processed by IndraDrive controllers in real time are stored in a motor data memory. These properties satisfy the divers requirements of modern automation.

- ▶ Powerful and compact
- ▶ High energy efficiency
- ▶ Increased torque accuracy
- ▶ Motor data memory with saturation and temperature data

Servo motor

MS2N07, MS2N10

Features

- ▶ Powerful and compact
- ▶ High energy efficiency
- ▶ Encoder in single- or multi-turn version
- ▶ Maximum torque up to 360 Nm
- ▶ Maximum speed up to 9000 rpm
- ▶ Optionally liquid-cooled with stainless steel pipes

Product description

The Rexroth MS2N motors are part of a completely newly developed motors series which comprises more than 50 motor types. Due to the optimized electro-magnetic design, the motors of the MS2N series achieve a high power density. Due to the introduction of the motor data memory in which individual measured values as well as saturation and temperature data are stored, these data are processed by IndraDrive controllers in real time. These properties satisfy the divers requirements of modern automation.

Differences as compared to MSK71 / MSK101

- ▶ Increased torque accuracy
- ▶ Single-cable connection for MS2N07
- ▶ Two-cable connection for MS2N07/10
- ▶ Saturation and temperature data stored in the motor data memory
- ▶ Less space required



Detaillierte Informationen:

Katalog: R999000018

Technical data

Type			MS2N07	MS2N10
Maximum speed	n_{\max}	rpm	6000	6000
Permanent torque with fan	M_0	Nm	12.8 ... 29.2	30.2 ... 85.0
Maximum torque	M_{\max}	Nm	30.8 ... 120	76.8 ... 313
Continuous current with fan	I_0	A	7.2 ... 19.1	12.6 ... 31.9
Maximum current	I_{\max}	A	25.9 ... 92.3	38.5 ... 140
Moment of inertia	J	kgm ²	0.00120 ... 0.00300	0.00480 ... 0.01740
Flange size	A	mm	140	196
Motor length	O	mm	326 ... 442	336 ... 510
Max. motor height	H	mm	upon request	297
Shaft diameter	D	mm	32	38
Weight		kg	12.0	23.5

Synchronous servo motor

MSK133

Features

- ▶ Maximum torque of up to 631 Nm
- ▶ Optional axial or radial fan
- ▶ Protection class: IP65
- ▶ Choice of cooling systems
- ▶ Fan cooling
- ▶ Optionally liquid-cooled with stainless steel pipes (MSK133)
- ▶ Compact and powerful
- ▶ Broad performance range
- ▶ Multiple models to match different load requirements
- ▶ Maximum speed up to 6000 rpm

Product description

Outstanding functions of the MSK range of motors include broad power range and model variants to match different load requirements. Encoders are available as single-turn version with motor data memory and as resolver. Additional options include shaft fitting key grooves, holding brakes, and increased radial runout to match any application. For applications with high continuous power operation, axial and radial fans are available.



Detailed information:

Catalog R999000019

Technical data

Type			MSK133
Maximum speed	n_{\max}	rpm	3300
Permanent torque with fan	M_0	Nm	152 ... 293
Maximum torque	M_{\max}	Nm	320 ... 631
Continuous current with fan	I_0	A	63 ... 115
Maximum current	I_{\max}	A	160 ... 305
Moment of inertia	J	kgm ²	0.0476 ... 0.09
Flange size	A	mm	260
Motor length	O	mm	582 ... 732
Max. motor height	H	mm	370
Shaft diameter	D	mm	48
Weight		kg	91.6 ... 146.0

Standard asynchronous motors

MOT-FC

Features

- ▶ Motor design according to DIN EN 60034 (IEC72)
- ▶ Standard asynchronous motors – MOT-FC...EV2/ET2 for use outside the North American market and special types (MOT-FC...NV3/NT3) for the North American market
- ▶ Protection class: IP55
- ▶ For use with frequency converters or IndraDrive, Bosch Rexroth recommends MOT-FC type standard asynchronous motors for FcP, DRn und SY(H)DFEn

Product description

Three-phase cage runner motors for operation at the frequency converter (inverter).

Rexroth's MOT-FC motor family is optimized for use in FcP, DRn and SY(H)DFEn systems with frequency converters.



Detailed information:

see R911343624

Technical data

Mechanical version		IEC
Power range	kW (hp)	0,25 ... 315 (0.3 ... 420 hp)
Nominal voltage	V	< 3 kW (230/460 V); > 3 kW (400/690 V)
Number of poles 1500 rpm		4
Energy efficiency		IE2
Design (EN 60034-7)		IM B35; IM B5, IM V1
Housing material		Aluminum (0.25 ... 7.5 kW), gray cast iron (from 11 kW)
Cooling (EN 60034-6)		IC 411 / TEFC (self-ventilated); IC 416 / TEBC (forced-ventilated)
Permitted ambient temperature	°C	-20 ... +40
Admissible installation height	m	1000
Motor/winding protection (DIN EN 60947-8)		PTC
Terminal box position (IEC 60034-7 AMD 1)		above

Pumps

Internal gear pumps

Internal gear pumps of type PGF1-2X/PGH-2X /PGH-3X are suitable for use in Sytronix systems. In open hydraulic circuits, they are suitable for a maximum continuous pressure of 210 bar or 315 bar, depending on the type. Reversing is possible in 2-quadrant operation. Internal gear pumps are the perfect solution for low noise requirements and use in pressure holding operation due to low internal leakage.

Axial piston pumps

The series A4 and A10 axial piston pumps are also suitable for use in Sytronix systems.

The adjustable axial piston pumps can be operated in pressure-holding operation at minimum speed for an unlimited period of time as lubrication and cooling are ensured thanks to the leakage port. They also deliver flow in both directions for closed circuits and can additionally be used as motors.

The A4 series axial piston pumps are very robust and have proven successful in many press line applications due to large displacements and pressure capability up to 400 bar. Suitable for extended pressure holding functions, these pumps are ideal for use in Sytronix drives thanks to an external leakage drain and wide range of drive speeds.

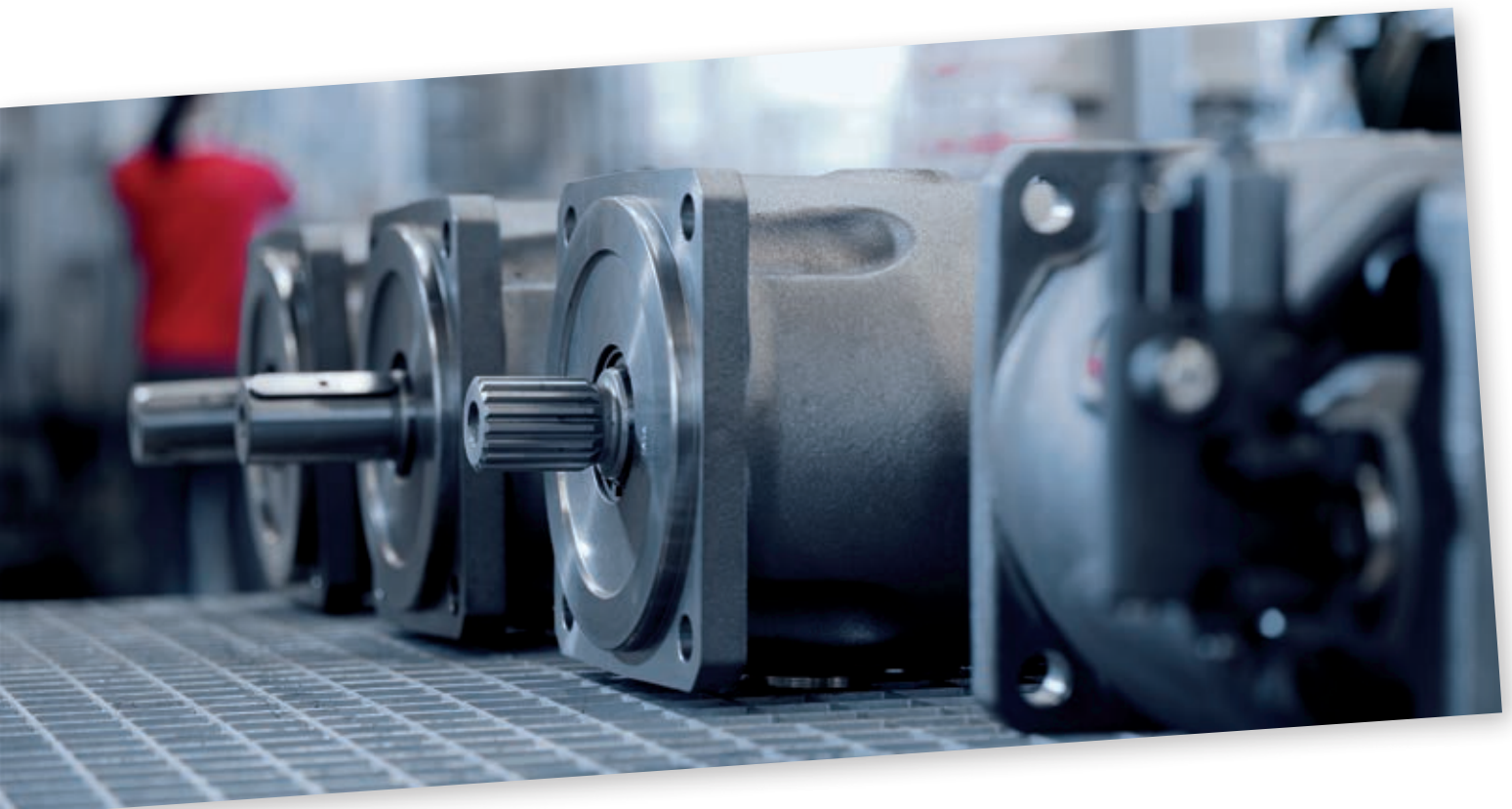

Internal gear pump

PGF-2X

Features

- ▶ Fixed displacement
- ▶ Low operating noise
- ▶ Low flow ripple
- ▶ High efficiency
- ▶ Long life cycle
- ▶ Suitable for a wide range of viscosities and speeds
- ▶ Very good suction characteristic
- ▶ Can be used in a variety of system sizes and combinations
- ▶ Can be combined with other pumps

Product description

PGF constant displacement internal gear pumps are pressure-relieved to minimize internal leakage. They are suitable for low to medium power Sytronix drives, and mid-pressure operation in industrial applications, such as machine tools.



Detailed information:

Data sheet RE 10213

Technical data

Type			PGF-2X	
Frame size			1	2
Size			1.7 ... 5	6 ... 22
Displacement		cm ³	1.7 ... 5	6.5 ... 22.0
Pressure	p _{nom}	bar	180 ... 210 ¹⁾	180 ... 210 ¹⁾
	p _{max}	bar	210 ... 250 ¹⁾	210 ... 250 ¹⁾
Speed	n _{min}	rpm	200	200
	n _{max}	rpm	3600 ... 4500	3600
Flow ²⁾	q _v	l/min	2.4 ... 7.2	9.4 ... 31.9
Liquid			HL mineral oil (DIN 51524 part 1) HLP mineral oil (DIN 51542 part 2) HEES liquids (DIN ISO 15380) HEPR liquids (DIN ISO 12380)	HL mineral oil (DIN 51524 part 1) HLP mineral oil (DIN 51542 part 2) HEES liquids (DIN ISO 15380) HEPR liquids (DIN ISO 12380)
Temperature	HLP fluid	°C	-20 ... +100	-20 ... +100
	Environment	°C	-20 ... +60	-20 ... +60
Filter class		Class	20/18/15	20/18/15

¹⁾ Pressure depends on size, see data sheet RE 10213

²⁾ Measured at n = 1450 rpm and p = 10 bar

Internal gear pump

PGH-2X

Features

- ▶ Fixed displacement
- ▶ Low operating noise
- ▶ Low flow ripple
- ▶ High efficiency at low speeds and viscosities due to dynamic pressure compensation
- ▶ Suitable for a wide range of viscosities and speeds
- ▶ Can be used in a variety of system sizes and combinations
- ▶ Size 2: Size 5 to 8
- ▶ Size 3: Size 11 to 16
- ▶ Maximum pressure: 350 bar
- ▶ Maximum displacement: 16 cm³
- ▶ Series 2X

Product description

PGH constant displacement internal gear pumps are pressure-relieved to minimize internal leakage. The driven pinion shaft is supported by hydrodynamic bearings and drives a gear rim with internal gearing. The liquid is pumped within the cavities and a sickle-shaped segment in the gear. The axial seals are dynamically pressure-relieved to ensure optimal sealing of the pump gears.



Detailed information:

Data sheet RE 10223

Technical data

Type			PGH-2X	
System size			2	3
Size			5 ... 8	11 ... 16
Displacement	V _g	cm ³	5.24 ... 8.2	11.0 ... 16.0
Speed	n _{min}	rpm	600	600
	n _{max}	rpm	3000	3000
Flow ¹⁾	q _v	l/min	7.5 ... 11.8	15.8 ... 23.0
Pressure	p _{nom}	bar	315	315
	p _{max}	bar	350	350
Temperature	HLP fluid ²⁾	°C	-10 ... +80	-10 ... +80
	Environment	°C	-20 ... +80	-20 ... +80
Filter class		Class	20/18/15	20/18/15

¹⁾ Measured at n = 1450 rpm and p = 10 bar

²⁾ HLP mineral oil (DIN 51524) part 2

Internal gear pump PGH-3X

Features

- ▶ Fixed displacement
- ▶ Low operating noise
- ▶ Low flow ripple
- ▶ High efficiency, even at low speeds and viscosities due to dynamic pressure compensation
- ▶ Suitable for a wide range of viscosities and speeds
- ▶ Suitable for operation with HFC fluid
- ▶ For more information on hydraulic fluids, refer to the data sheet
- ▶ Size 4: Size 20 to 50
- ▶ Size 5: Size 63 to 250
- ▶ Maximum pressure: 350 bar
- ▶ Maximum displacement: 250 cm³
- ▶ Series 3X
- ▶ Pump with cast iron housing

Product description

PGH constant displacement internal gear pumps are pressure-relieved to minimize internal leakage. The driven pinion shaft is supported by hydrodynamic bearings and drives a gear rim with internal gearing. The liquid is pumped within the cavities and a sickle-shaped segment in the gear. The axial seals are dynamically pressure-relieved to ensure optimal sealing of the pump gears.



Detailed information:

Data sheet RE 10227

Technical data

Type			PGH-3X	
System size			4	5
Size			20 ... 63	63 ... 250
Displacement	V_g	cm ³	20.1 ... 65.5	64.7 ... 250.5
Speed	n_{min}	rpm	200	200
	n_{max}	rpm	3000	3000
Flow ¹⁾	q_v	l/min	28.9 ... 94.1	92.8 ... 359.6
Nominal pressure, continuous pressure	p_N	bar	210 ... 315	135 ... 315

¹⁾ Measured at $n = 1450$ rpm and $p = 10$ bar

Axial piston pumps

A10FZO, A10FZG, A10VZO, A10VZG

Features

- ▶ Suitable for variable-speed operation
- ▶ Suitable for start/stop operation
- ▶ Suitable for long pressure holding operation
- ▶ Possible applications as pump or motor
- ▶ Mineral oil (HL, HLP) according to DIN 51524, part 2
- ▶ Proven A10 technology
- ▶ Optional through-drive
- ▶ High efficiency
- ▶ Controllers for pressure control (DRn), torque limitation (DRn) and two-point adjustment (FCP/SVP) available

Product description

As an advanced design of the proven A10 family of pumps, these products are the perfect solution for applications with frequency converters in energy-efficient systems.

Axial piston pumps of series A10 are available as fixed displacement pumps in open (A10VSO VZO/FZO) or closed (A10VSO VZG/FZG) circuits, or as variable displacement pumps in open (A10VZO) or closed (A10VZG) circuits.



Detailed information:

Data sheet RE 91485

Axial piston pumps

A4VSO

Features

- ▶ Variable displacement
- ▶ Very good suction characteristic
- ▶ Low noise
- ▶ Long life cycle
- ▶ Hydraulic/mechanical pressure controller
- ▶ HFC operation with a special version, see RE 92053
- ▶ Mineral oils and HFD hydraulic fluids
- ▶ Modular design
- ▶ Fast control times
- ▶ Universal through-drive for setting up pump combinations
- ▶ Visual swivel angle indicator
- ▶ Arbitrary installation position
- ▶ Restrictions with regard to HF fluids

Product description

A4VSO axial piston variable displacement pumps feature a swashplate and are suitable for open circuit operation.



Detailed information:

Data sheet RE 92050

Technical data

Type			A4VSO
Size			40 ... 750
Displacement		cm ³	40 ... 750
Pressure	p _{nom}	bar	350
	p _{max}	bar	400
Speed	n _{min}	rpm	50 min-1, in DRn operation 500 min-1 reasonable
	n _{max}	rpm	3200 ... 1500 min-1
Flow ¹⁾	q _v	l/min	1125
Pump operation			Yes
Motor operation			No
Performance (Δp = 350 bar; V _{g,max} ; n = 1500 rpm)	P _{max}	kW (hp)	35 ... 656 (47 ... 880)
Torque (Δp = 350 bar, V _{g,max})	M _{max}	Nm	223 ... 4174

¹⁾ Measured at n = 1500 rpm

Variable-speed pressure and flow control system

SYDFEn

Features

- ▶ Pump preload valve SYDZ (optional)
- ▶ Axial piston variable displacement pump A10VSO ... /32
- ▶ Proportional valve VT-DFPn-2X with integrated electronic control system
- ▶ Swivel angle sensor
- ▶ Mineral oil (HL, HLP) according to DIN 51524, part 2
- ▶ With pulsation damping, optional
- ▶ Real-time mode for non-cyclic processes, “Teach-in mode” for cyclic processes
- ▶ Versions for increased speed available optional
- ▶ Variable through-drive

Product description

The SYDFEn control system serves the electro-hydraulic control of displacement, pressure and power/torque of an axial piston pump. Thanks of the integrated speed calculation, the optimum efficiency of the SYDFEn system can be achieved.



Detailed information:

Data sheet RE 30630

Technical data

Type	SYDFEn						
Size			45	71	100	140	180
Displacement	$V_{g \max}$	cm ³	45	71,1	100	140	180
Max. speed	$n_{0 \max}$	rpm	3000	2550	2300	2200	1800
Min. speed	n_{\min}	rpm	50	50	50	50	50
Max. flow at max. speed	$q_{v0 \max}$	l/min	135	181	230	308	324
Max. flow at $n_E = 1500$ rpm		l/min	67,5	106,7	150	210	270
Max. performance ($\Delta p = 280$ bar) at max. speed	$P_{0 \max}$	kW (hp)	62,8 (84,1)	84 (113)	107 (143)	144 (193)	151 (202)
Max. performance ($\Delta p = 280$ bar) at $n_E = 1500$ rpm		kW (hp)	31 (42)	50 (67)	70 (94)	98 (131)	125 (168)
Weight (without through-drive, incl. pilot valve)	m	kg	32	49	71	75	80
Nominal pressure	p_{nom}	bar	280	280	280	280	280
Min. operating pressure without pre-load valve	p_{\min}	bar	≥20	≥20	≥20	≥20	≥20
Min. operating pressure with pre-load valve	p_{\min}	bar	>0	>0	>0	>0	>0

Variable-speed pressure and flow control system SYHDFEn

Features

- ▶ Axial piston variable displacement pump A4VSO
- ▶ Proportional valve VT-DFPn-2X with integrated electronic control system
- ▶ Swivel angle sensor
- ▶ Suitable for HFC fluids according to RE 92053 optional
- ▶ Mineral oil according to DIN 51524 (HL/HLP)
- ▶ Real-time mode for non-cyclic processes, “Teach-in mode” for cyclic processes
- ▶ Universal through-drive

Product description

The SYHDFEn control system serves the electro-hydraulic control of displacement, pressure and power/torque of an axial piston pump. Thanks of the integrated speed calculation, the optimum efficiency of the SYHDFEn system can be achieved.



Detailed information:

Data sheet RE 30035
Leitfäden zur Nachrüstung von A4VSO-Pumpen
Datenblatt: RD 30637

Technical data

Type	SYHDFEn							
Size			40	71	125	180	250	355
Displacement	$V_{g\ max}$	cm ³	40	71	125	180	250	355
Max. speed	$n_{0\ max}$	rpm	2600	3600	1800	2600	1800	1500
Min. speed	n_{min}	rpm	200	200	200	200	200	200
Max. flow at max. speed	$q_{v0\ max}$	l/min	104	255	225	468	450	533
Max. flow at $n_E = 1500$ rpm		l/min	60	107	186	270	375	533
Max. performance ($\Delta p = 350$ bar) at max. speed	$P_{0\ max}$	kW (hp)	61 (82)	91 (122)	131 (176)	273 (366)	263 (353)	311 (417)
Max. performance ($\Delta p = 350$ bar) at $n_E = 1500$ rpm		kW (hp)	35 (47)	62 (83)	109 (146)	158 (212)	219 (294)	311 8417
Weight (without fluid)	m	kg	39	56	88	102	184	207
Suction pressure	p	bar	0,8	0,8 ... 30	0,8 ... 30	0,8 ... 30	0,8 ... 30	0,8 ... 30
Max. admissible operating pressure	p_{max}	bar	350	350	350	350	350	350
Min. operating pressure without pre-load valve	p_{min}	bar	>20	<20	≥20	≥20	≥20	≥20
Min. operating pressure with pre-load valve	p_{min}	bar	≥0	≥0	≥0	≥0	≥0	≥0

Accessories



Mains filters

Mains filters ensure that the EMC limit values are adhered to and suppress leakage current generated by capacitors.

Braking resistors

Braking resistors provide energy conversion into heat by means of dynamic braking of the drive.

Mains choke

Mains chokes reduce the harmonics coupled into the supply network. As an IndraDrive accessory, these devices are used to increase the continuous DC bus power and to suppress harmonics.

Power and encoder cables

Power cables are used to connect the motor to the drive unit. Encoder cables are used to connect the feedback encoder to the drive unit.

Auxiliary components

Accessories for the electrical and mechanical connection of the Sytronix system, such as busbars, shielded motor cables, mounting flanges and commissioning accessories.

Control cabinets

CAB-X is a standard solution for European Countries for hydraulic power unit controls with Rexroth EFC 5610 for FcP 5020 Sytronix systems.

Detailed information:

Catalog R999000019

Pressure transducers for hydraulic applications HM20-2X

Features

- ▶ Sensor with thin-film technology
- ▶ Stainless steel surfaces
- ▶ Enhanced reliability including high burst pressures, reversed polarity, overvoltage and short-circuit protection
- ▶ Excellent temperature characteristics
- ▶ UL approval for the US and Canadian market
- ▶ 8 pressure levels available
10/50/100/160/250/315/400/630
- ▶ Electrical connection: Connector, 4-pole, M12x1

Product description

Pressure transducers are used for measurement and control in hydraulic systems. The measured pressure is converted into a linear electrical output signal. Voltage 0,1 – 10 V (HM20...H...) or 4 – 20 mA versions (HM20...C...) available.



Detaillierte Informationen:

Datenblatt: RD 30272

Technical data

Type	HM20-2X		
Operating voltage	U	V DC	16 ... 36
Output signals	U	V	0.1 ... 10
	I	mA	4 ... 20
Pressure range	p	bar	0 ... 10/50/100/160/250/315/400/630
Accuracy class			0.5
Settling time (10 to 90 %)	t	ms	< 1
Temperature coefficient	T _c	%	< 0.1/10 K
Fluid temperature range	T _{Fluid}	°C	-40 ... +90
Ambient temperature range	T _{Ambient}	°C	-40 ... +85
Protection class			IP65/IP67
Electrical connection			M12 connector, 4-pole
Pressure port			G1/4

Control cabinet CAB-X standard for hydraulic power unit Sytronix FcP 5020 (European Countries)

Features

- ▶ Control cabinet size according to frequency converter RAL7035
- ▶ Complete motor supply including frequency converter EFC 0.37 ... 160 kW (0.5 ... 200 hp) or servo-drive HCS up to 350 A
- ▶ Thermistor and pump guard function
- ▶ Regulated power supply unit with 24 VDC
- ▶ Control transformer 400/230 VAC (EFC5610 > 55 kW (75 hp))
- ▶ Circuitry, emergency stop
- ▶ Circuitry external control motor start/stop
- ▶ Monitoring of the minimum oil level (indicator light and shut-off function)
- ▶ Monitoring of the maximum oil level (indicator light and shut-off function)
- ▶ Monitoring of the maximum oil temperature (indicator light and shut-off function)
- ▶ Oil filter monitoring (indicator light)
- ▶ Interface for integration in a machine control (terminal strip)
- ▶ External command value (oil pressure, oil flow)
- ▶ Main switch
- ▶ Emergency off button



Please contact sytronix.support@boschrexroth.de for an individual offer

Product description

CAB-X is a standard solution for hydraulic power unit controls with Sytronix systems.

Bosch Rexroth AG

Zum Eisengießer 1
97816 Lohr, Germany
www.boschrexroth.com/sytronix



Find your personal contact person here

We are here for you! A directory with your direct and local Rexroth contact can be found online at:
www.boschrexroth.com/contact



Sytronix online

Here you will find videos and tools as well as configurators and selection guides to download:
www.boschrexroth.com/sytronix



Rexroth Media Directory

Here is your 24/7 source for promotional media and technical documentation. Search and download information:
www.boschrexroth.com/mediadirectory

© This document and the data, specifications and other information contained therein are the exclusive property of Bosch Rexroth AG. Reproduction or transfer to third parties is not permitted without their consent.

The data specified above only serve to describe the product. As our products are constantly being further developed, no statements concerning a certain condition or suitability for a certain application can be derived from our information. The information given does not release the user from the obligation of own judgment and verification. It must be remembered that our products are subject to a natural process of wear and aging.

Material no.: R999000332 (2019-10)
© Bosch Rexroth AG 2019
Subject to revisions!

